

Insertion Electromagnetic Flow meter
GT300-INT

Operation & maintenance Manual

Content

| | |
|--|----------|
| Applications and Characteristics | |
| Structure and Working Principle | 3 |
| Technical Parameters | |
| Installation: inserting and taking out | 4 |
| Adjustment of depth of penetration | |
| Wiring | 5 |
| Implementation | |
| Balanced supply and Quality guarantee | |
| Transportation, Goods checking and Storage | |
| Ordering notes | |

Applications and Characteristics

Applications

The GT300 series insertion electromagnetic flow sensor (short follow), with S200 or Battery type/ Remote type electromagnetic makes up the insertion electromagnetic flow meter.

Normally the insertion GT300-INT are remote type, if requested, are also available.

The sensor of compact type GT300-INT is often installed at the flow is measured, while that of remote type is usually mounted or in instrument box with support or between instrument and controller (they are connected by a special cable). GT300-INT is widely applied in department like industry, agriculture, water conservation, environmental protection, water supply, etc. to measure and control the flow of various kinds of conducting liquid.



as "sensor" as flow transmitter,

the compact type

pipeline in which the on the wall nearby

Characteristics

The characteristics of GT300-INT are the same as that of duct GT300, as follow:

- a) The measurement is not affected by the density, viscosity, and temperature, pressure and electro conductivity of fluid;
- b) There are no obstacles or loss of pressure in the measuring pipe, low requirements for straight pipe;
- c) The nominal diameter is from DN80 to DN2400 for this series.
Multiple choices are available for the liner of converter and the material of electrode;
- d) Adopt a novel way of excitation, low power consumption, stable zero point and high accuracy.
The flow range ability is up to 50:1;
- e) Converter and transmitter together can be made up into two forms of flowmeter: compact-type and remote-type;
- f) A 16-bit high-performance microprocessor is adopted into the converter, it has a 2*16LCD displayer, the parameters are easy to set and the programming is reliable;
- g) The measuring system in the flowmeter is bidirectional and with three integrators inside: positive total, reverse total and difference value total. The positive total and reverse total are both displayable. It also has multiple ways of output: electric current, pulse; digital communication, HART;
- h) The mounting technology of converter is surface mount technology (SMT) which possesses self-check and self-diagnose functions;
- i) The structure of transducer with rubber liner and transducer with FEP, Polyurethane liner are all submerged;
- j) The explosion-proof instrument can be used at relevant explosion-proof sites;

Structure and Working Principle

Structure

Fig.1 and fig.2 show the two kinds of structures of sensor.

The top part of the structure drawing is junction box, together with electromagnetic flow converter and with special cable between them, make up remote type GT300-INT; if the junction box is replaced by a electromagnetic flow converter, it is compact type.

From the drawings we can see that sensor is made up of:

- a) Detector: including electrode, magnet exciting coil, iron core and lead wire, shell material is PVC or F4;
- b) Inserted rod: used to connect detector and converter, made up from 304 or 316 stainless steel;
- c) Installation parts: ($\Phi 60 \times 3$) 304 or 316 S.S., welded onto customer piping;
- d) Valve or Pup joint: 2" S.S. Ball valve or pup joint, used to move out or install sensor without setting-off;
- e) Sealing and locking mechanism: including transition piece, gland nut and special silicon seal;
- f) Junction box: where the exiting current and signal of sensor and converter are correspondingly linked.

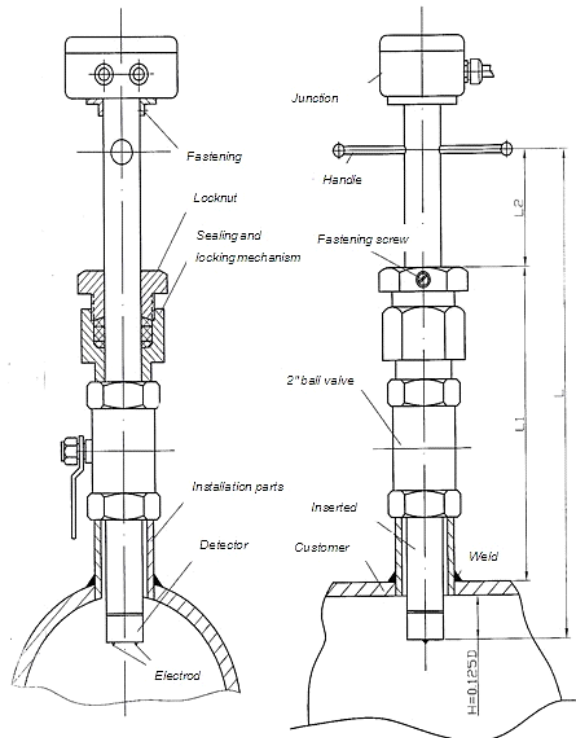

Fig1. The whole structure drawing of sensor with ball valve

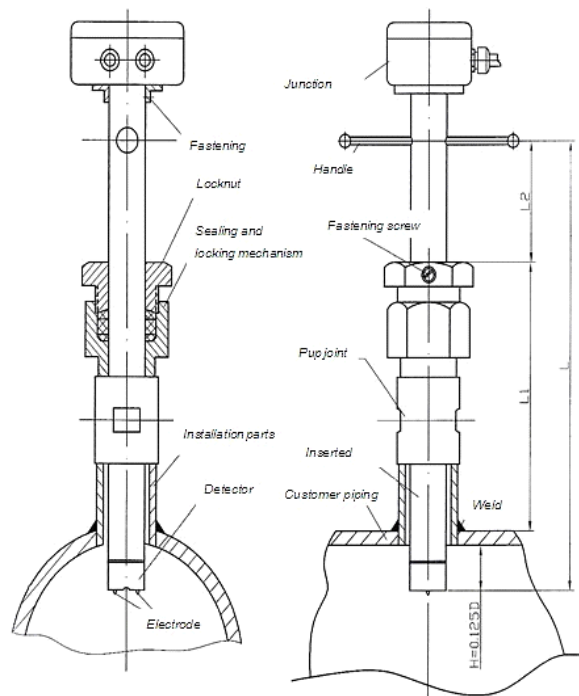

Fig2. The whole structure drawing of sensor without ball valve

Working principle

Same as duct GT300, the working principle of inserted GT300-INT is based on the electromagnetic induction law of Faraday.

When the conducting liquid flows perpendicularly to the magnetic line of force with a magnetic field strength B

and though two electrode with a distance L at a flowrate V, a relative electrodynamic force E is created.

$$\text{The electromagnetic law of Faraday is: } E = B \times L \times V \quad (1)$$

$$\text{The volume flow rate is: } Q_v = \pi/4 \times D^2 \times V \quad (2)$$

As the size of sensor is certain, if the diameter of installing pipe is known, After calibration, there is a positive relationship between Q and E:

$$Q_v = K \times E \quad (3)$$

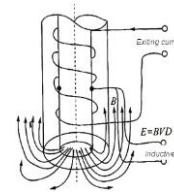

Therein:

K: meter coefficient $K = \pi D^2 / 4BL$

B: magnetic field strength of magnetic exiting coil

L: the distance between the two electrodes

V: the average flow rate

Q_v : the volume flow rate of the measured fluid

The meter coefficient K is calculated from calibration and will be placed into converter, it can not be changed.

Technical Parameters

- Nominal diameter: DN 80~2400mm
- Working pressure: ≤ 1.6 MPa
- Flow rate measuring range: 0~1m/s to 0~10m/s, full scale within 1~10m/s range continuously adjustable.
- Measurement accuracy: when the full scale flow rate > 0.5m/s, $\pm 1.5\%$
- Measured medium conductivity: ≥ 20 us/cm
- Measuring tube (head) material: ABS
- Measuring pipe material: Carbone steel, SUS304.
- Electrode material: SUS316L, Hastelloy C, Tantalum,
- Ambient temperature: -10 ~ +55°C
- Shell protection degree: IP65, IP68
- DC current: ~10mA load resistance is 0~1k Ω
- 4~20mA load resistance is 0~500 Ω
- Frequency: 1~5kHz load resistance is 250 Ω ~1.2k Ω
- Communication interface: RS232/ RS485, HART
- Converter power supply type: 85~220VAC, 24VDC, 3.6V battery powered
- Connection method: Flanged, Threaded connection

Installation: Inserting and taking out

As there is a outward thrust on the detecting rod from the pressure in pipeline, for safety's sake, the installation is better under outage status, that means under pressure-free condition; if outage is not allowed, please lower the

pressure under 0.2MPa.

Please check if you receive the right product before installation, if there is a mistake, please contact us immediately.

Please proceed the installation according to the following steps:

As shown in fig.1 and fig.2, move the detecting rod till electrode and the bottom end of installation part are in the same level, then make a record of the depth that the detecting rod inserted into the tube as L2.

Inserting

- a) The customer piping should be horizontal, there should be at least 10DN straight pipe in the upstream of sensor and 5DN in downstream. The regulating valve should be at least 5DN away from sensor in the downstream;
- b) Open a $\phi 60\sim 62$ mm bore right above the measuring point of the pipeline, the edge of the bore should be bright and clean, no burrs and gas cutting scar;
- c) Remove the installation part from the sensor and securely weld them to the mentioned bore, make sure its lower extreme is in the same section with the inner surface of pipeline and no leakage;
- d) Loosen the three lock screws from sensor, pull the detecting rod and detector out as a whole body for the following installation. Please don't unbolt the joint between detector and inserted rod;
- e) Twine the top of installation part with flax oil lead or FEP plastic tape, screw a ball valve with seal and locking mechanism onto it;
- f) Slowly insert the detecting rod from the above, then screw the locknut, press the detecting rod until the L2 is the same as the recorded L2. The installation is down.

Taking out

- a) Loosen the three set screws aside the locknut, then slightly loosen the locknut in order to loosen the seal ring and pull out the inserted rod;
- b) Lift the handle to pull the inserted rod up about 250mm, then close the ball valve, the inserted rod can be pull out.

Adjustment of depth of penetration

- When choosing to insert electrode to the average velocity point, as under the turbulence condition in the tube, the average velocity point is approximately $H1=0.25D$ away from the tube wall, please press the inserted rod into the tube about H1 deep;
- When the mentioned depth is confirmed to be right, turn the handle to make the connecting wire parallel to the centre line of tube. At this time, the connecting wire is perpendicular to the centre line of tube, that means it is perpendicular to the flow direction;
- After adjusting, tighten the locknut and then the three lock screws to make sure that the inserted rod not be pushed out by the tube pressure and not to vibrate(when tightening the first two lock screws, stop right when they reach the inserted rod, and for the third one, make sure it is securely tightened);
- When choosing to insert electrode to the centre of the tube (the max. flowrate point), the pressing depth should be $H=0.5D$. Other operating conditions are the same as above;
- Loosen the lock screw below the junction box, turn the junction box until it is fit for customer's need, then tighten the lock screw.

Wiring

The two connecting wires between sensor and converter are RVVP dual-core shielded cable, fig.4 shows the

wiring status.

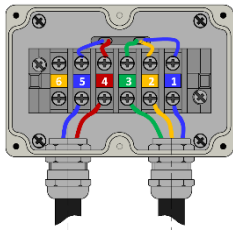

| Port No. | Wire | Converter Port |
|----------|-----------------|----------------|
| 1 | Signal 1 | SIG1 |
| 2 | Signal 2 | SIG2 |
| 3 | Com | SGND |
| 4 | Field current 1 | EXT+ |
| 5 | Field current 2 | EXT- |
| 6 | Reserve | N.A. |

Fig.4 the wiring diagram of junction box

Implementation

- Set up of inserted GT300-INT: the inserted electromagnetic flow sensor can only implement the measurement when working with a converter. Please make sure you order a whole set.
- Since the calibration of inserted GT300-INT is through a certain pipeline, which may not be different from the customer's, how to confirm the upper limit of flowrate could be a issue. So please get to know the below table--the comparison table of several commonly used DN size, average velocity (m/s) and volume flow (m³/h).

| DN (mm) (Inch) | | Velocity (m/sec) | | | | | |
|-------------------|------|------------------|---------|---------|----------|----------|---------|
| | | 0.5 | 1.0 | 1.5 | 2.0 | 2.5 | 3.0 |
| 300 | 12 " | 127.2 | 254.4 | 381.6 | 508.8 | 636.0 | 763.2 |
| 350 | 14 " | 173.1 | 346.2 | 519.3 | 692.4 | 865.5 | 1,038.6 |
| 400 | 16 " | 226.1 | 452.2 | 678.3 | 904.4 | 1,130.5 | 1,356.6 |
| 450 | 18 " | 286.2 | 572.3 | 858.3 | 1,144.6 | 1,430.8 | 2,574.9 |
| 500 | 20 " | 353.3 | 706.5 | 1,059.8 | 1,413.2 | 1,766.5 | 2,119.8 |
| 600 | 24 " | 508.7 | 1,017.0 | 1,526.0 | 2,034.0 | 2,544.0 | 3,052.0 |
| 700 | 28 " | 682.4 | 1,385.0 | 2,047.0 | 2,730.0 | 3,412.0 | 4,094.0 |
| 800 | 32 " | 904.3 | 1,808.0 | 2,713.0 | 3,617.0 | 4,522.0 | 5,126.0 |
| 900 | 36 " | 1,145.0 | 2,290.0 | 3,435.0 | 4,580.0 | 5,725.0 | 6,870.0 |
| 1000 | 40 " | 1,413.0 | 2,826.0 | 4,239.0 | 5,652.0 | 7,065.0 | 8,478.0 |
| 1200 | 48 " | 2,034.0 | 4,068.0 | 6,102.0 | 8,136.0 | 10,170.0 | |
| 1400 | 56 " | 2,770.0 | 5,540.0 | 8,310.0 | 11,080.0 | 13,850.0 | |

- When choosing to insert electrode to the average velocity point, according to the above table, calibration sheet, technical parameters, the functions of converter, user manual, customer can then proceed the setting of parameters like flow, flowrate, etc., and then the inserted EMF can be put in use.
- When choosing to insert electrode to the central line of tube, the detected flowrate is the max. Flowrate V_{max} , which should be converted into the average flowrate V_{cp} .

Under turbulence condition, these two have a relationship as follows:

$$V_{cp} = K_1 V_{max} \quad (4)$$

Therein, $K_1 < 1$, is a coefficient related to Reynolds number R_{eD} , stated as below:

$$K_1 = \frac{2n^2}{(n+1)(2n-1)} \quad (5) \quad \begin{aligned} n &= 1.661gR_{eD} \\ R_{eD} &= 354 \times \frac{Q_m}{u^*D} \end{aligned}$$

Therein, Q_m : the mass flow rate of measured fluid (kg/h)
 μ : the dynamic viscosity of measured fluid (mPa.s)
 D : the inner diameter of pipeline (mm)

- From formula 4 we can see that, when the electrode of inserted flow sensor is at the central line of tube, without adjustment, the flowrate (flow) showed by electromagnetic flow converter is about $1/K_1$ larger than the correct average flowrate. Customers should be thoroughly know the parameters in order to correctly adjust them.
 In the above case, the adjustment should be reducing the instrument coefficient about K_i fold.
 Therefore, customers should better choose to insert the electrode of inserted flow sensor to the average velocity point in the pipeline.
- Blockage coefficient β

$$\beta_{0.125D} = \frac{4 \times 47 \times 0.125D}{\pi D^2} \quad (\text{the electrode is at the average velocity point})$$

$$\beta_{0.5D} = \frac{4 \times 47 \times 0.5D}{\pi D^2} \quad (\text{the electrode of inserted flow sensor is at the central line of tube})$$

As the inserted rod will increase the average velocity by decreasing the circulation area, the adjustment should be based on the β value.
 According to the experiments, when β value is less than 0.015, there is no need to do adjustment and the accuracy will not be affected.

DN=300, $\beta_{0.125D} = 0.026$
 DN=350, $\beta_{0.125D} = 0.021$
 DN=400, $\beta_{0.125D} = 0.018$
 DN=450, $\beta_{0.125D} = 0.015$

In this case, when DN=300 or DN=350, adjustment is necessary.
 As our calibration pipeline is DN400, it is not need to be adjusted.
 DN=600mm, $\beta_{0.5D} = 0.049 > 0.015$, adjustment is necessary, which is adjusting instrument coefficient.
 To avoid this adjustment, inserting the electrode to the average velocity point is recommended.

Balanced supply and Quality guarantee

- **Balanced supply**

- a) Products

- GT300-INT electromagnetic flow sensor -- 1 set
 - RVVP dual-core shielded cable) --- 5m (5m each for signal wire and excitation wire)
Please order more if not sufficient.
 - Electromagnetic flow transmitter --- 1 set

- b) Attached papers

- The user manual of GT300-INT electromagnetic flow sensor
 - The user manual of flow transmitter
 - Calibration sheet
 - Certificate of quality

- **Quality guarantee**

- Within one year from the date of delivery, any malfunction caused by ill manufacturing or substandard of elements, we will offer free maintenance, change of elements or the whole instrument.

Transportation, Goods checking and Storage

- **Transportation**

- The inserted GT300 provided by us will be packed in wooden cases to avoid moisture and shock, in which case applicable for any kinds of transportation/.

- **Goods checking**

- Please check the goods right after unpacking to see if the received instrument is in accordance with the packing list. If not, please contact us immediately to solve the problem.

- **Storage**

- After checking the goods, please pack them up as before. Please put the instruments that are not ready to be used in conditions as follow:

- Water proof; Moisture proof;

- Low mechanical vibration; Temperature: -20~+60°C; Relative humidity: less than 80%

Ordering notes

Please make sure you know the following specifications when ordering:

- a) The inner diameter or specification of pipeline;
 - b) The material of pipeline;
 - c) The pressure and temperature in the pipeline;
 - d) The name of fluid to be measured and its cleanness, corrosiveness.
 - e) Whether an electromagnetic flow converter is needed;
 - f) The length of extra needed cable.