



Mini Turbine Flowmeter GTG

Combined Temp & Flow sensor



Combined Temp & Flow sensor

Self-Lit OLED clear display

English + GUI easy menu

Dual output Digital + Analog

GTC Global Co., Ltd.

Tel: 82.53.762.6668 Fax: 82.53.355.7295
E-mail: gtcinfo99@gmail.com
Add.: 121-3, Yutongdanji-ro 8-gil, Buk-gu, Daegu, Korea 41515

1. Product Description

The schematic diagram of the **GTG_Mini Turbine Flowmeter** is shown.

A turbine is installed at the center of the pipeline, supported at both ends by bearings.

When the fluid passes through the pipeline, it impacts the turbine blades, causing the turbine to rotate, and the rotational speed of the turbine is proportional to the fluid flow velocity.

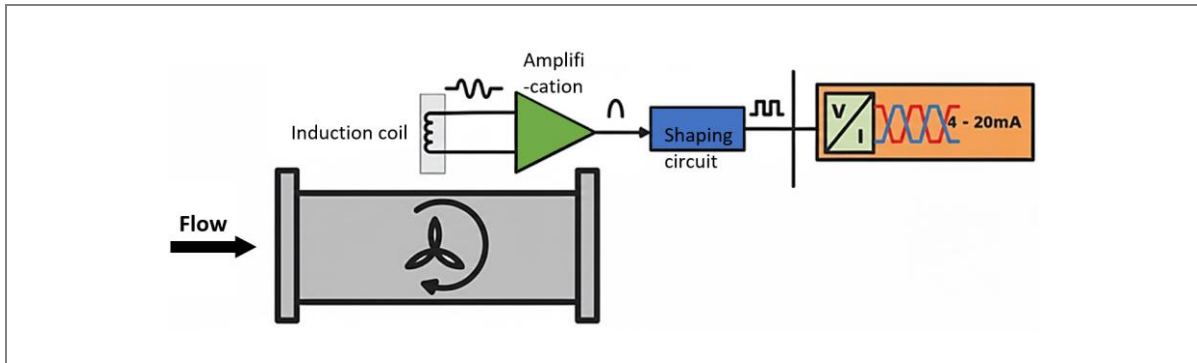

The liquid flow drives the turbine to rotate, cutting the magnetic field lines generated by the permanent magnetic steel inside the shell, resulting in changes in magnetic flux.

The sensing coil sends the detected magnetic flux periodic change signal to the preamplifier for amplification, generating a pulse signal proportional to the flow rate and calculating the flow rate value through circuit operation.

2. Product Features



● Integrated Temp & Flow Measurement	● Self-Illuminating OLED Display
● Smart Temp Display Alarm Contact Output	● Smart FLOW Display Alarm Contact Output
● Intuitive English GUI	● Digital Communication & Analog Integration
● High-Precision Probe Technology	● Anti-fouling Probe Scale/ Corrosion Resistant
● Fully Sealed Waterproof Housing	● High-Pressure pressure resistance: 10 MPa

The **GTG-Mini Turbine Flow meter** features a simple structure, high accuracy, and easy installation, maintenance, and operation.

It enables real-time monitoring of liquid flow and temperature in pipelines, providing flow measurement via 4-20mA or pulse signals with alarm switch outputs, and temperature measurement via 4-20ma signals with alarm switch outputs.

Equipped with an OLED real-time display for simultaneous visualization of flow rate and temperature, it achieves integrated monitoring of both parameters in pipelines.

Widely utilized in petrochemical, power, metallurgy, steel plants, papermaking, food processing, water treatment, and battery factories, this sensor ensures reliable performance in diverse industrial environments.

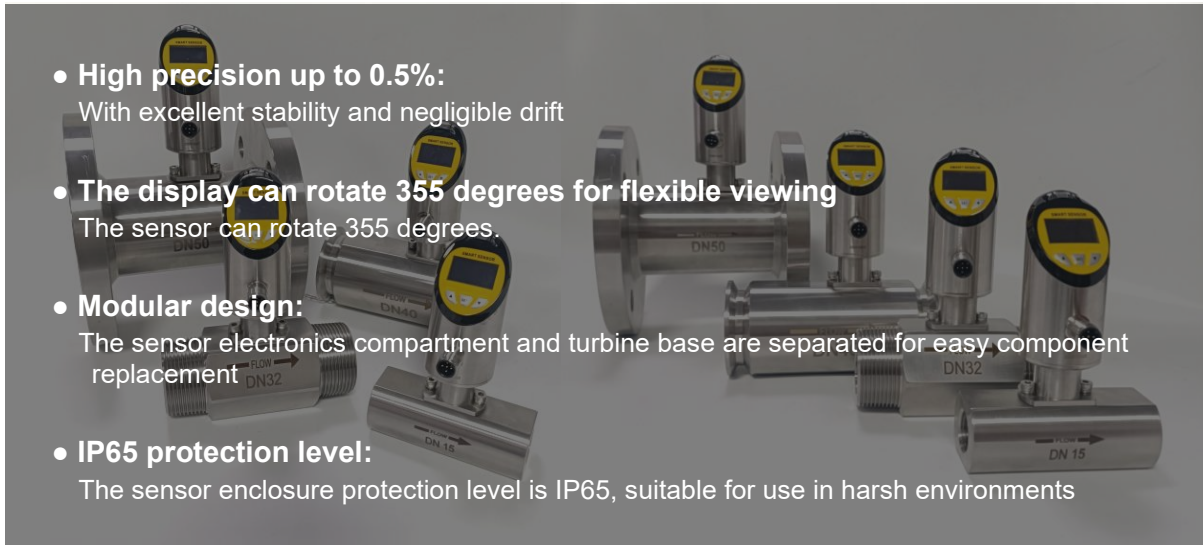

Detail presentation exemplifying quality

- **304 base aluminum alloy case**
Corrosion resistant, excellent anti-interference



- **Ruby bearing**
High hardness, wear-resistant

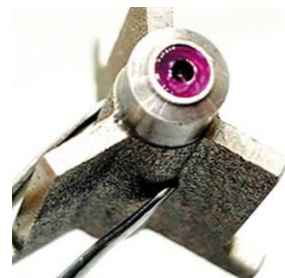

- **Tungsten alloy steel impeller**
High hardness, wear/corrosion resistant



Easy Installation



Three-step installation

- Install the sensor onto the detection port
- Adjust the display orientation
- Connect the cables

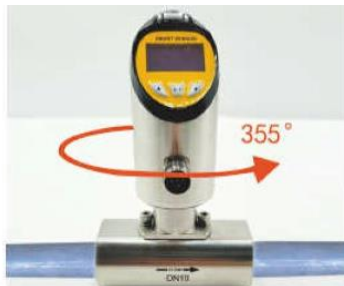
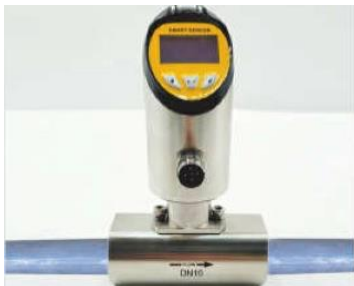

Easy maintenance

The sensor features a separated design for the electronics compartment and turbine base, enabling easy component replacement and maintenance.



Turbine Base



Electronics Compartment

The sensor's electronics compartment and turbine base are separated - simply replace whichever component is damaged.

3. Technical Specifications and Parameters

Flow	Measuring Range	See the comparison table below
	Accuracy	Class 0.5, Class 1, Class 2
	Switching time	Turn-on: ≤ 2s / Turn-off: ≤ 2s (1~2s)
Temp	Measuring Range	0 ~ 100°C (customizable)
	Resolution	±0.1°C
Power Supply & Consumption		24VDC / 3W
Output Supply & Consumption		1 alarm contact, 4-20mA analog / pulse output (configurable)
Alarm contact type		NPN / PNP
Insulation resistance		50MΩ @ 100VDC
Power consumption		3W (24VDC)
Interfaces		Thread/ Clamp/ Flange
Housing material		SUS304
Base material		SUS304
Environmental conditions		-20 ~ 85°C, <85% RH

Pipe diameter, measuring range, and pressure correlation table

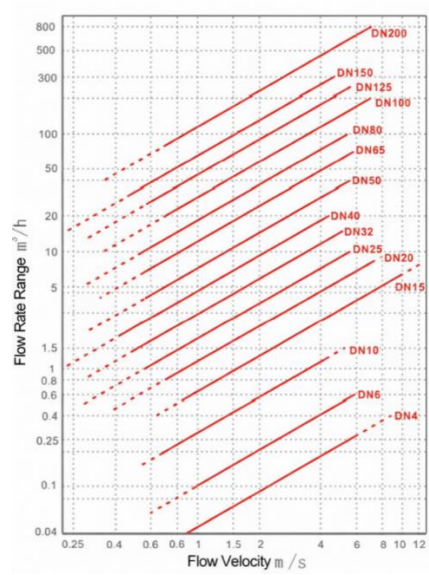
	Pipe Diameter	Normal Flow Range (m ³ /h)	Extended Flow Range (m ³ /h)	Standard Connection & Pressure Rating
	DN4	0.04~0.25	0.04~0.4	Thread/ 6.3MPa
	DN6	0.1~0.6	0.06~0.6	Thread/ 6.3MPa
	DN10	0.2~1.2	0.15~1.5	Thread/ 6.3MPa
	DN15	0.6~6	0.4~8	Thread/ 6.3MPa, Flange/ 2.5MPa
	DN20	0.8~8	0.45~9	Thread/ 6.3MPa, Flange/ 2.5MPa
	DN25	1~10	0.5~10	Thread/ 6.3MPa, Flange/ 2.5MPa
	DN32	1~15	0.75~15	Thread/ 6.3MPa, Flange/ 2.5MPa
	DN40	2~20	1~20	Thread/ 6.3MPa, Flange/ 2.5MPa
	DN50	4~ 40	2~40	Flange/ 2.5MPa
	DN65	7~ 70	3.5~70	Flange/ 2.5MPa
	DN80	10~100	5~100	Flange/ 2.5MPa
	DN100	20~200	10~200	Flange/ 1.6MPa
	DN125	25~250	12.5~250	Flange/ 1.6MPa
	DN150	30~300	15~300	Flange/ 1.6MPa
	DN200	80~800	40~800	Flange/ 1.6MPa

4. Installation and Configuration Diagram

4-1. Panel Introduction Interface & Controls



4-2. Dimension

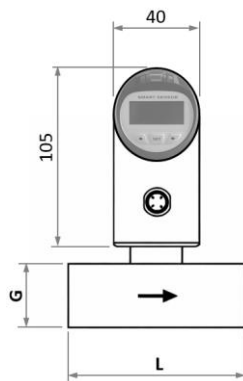

Nominal Diameter (mm)	L (mm)	G (Internal Thread)
4	80	G1/4"
6	80	G1/4"
10	80	G1/4"
15	80	G1/2"

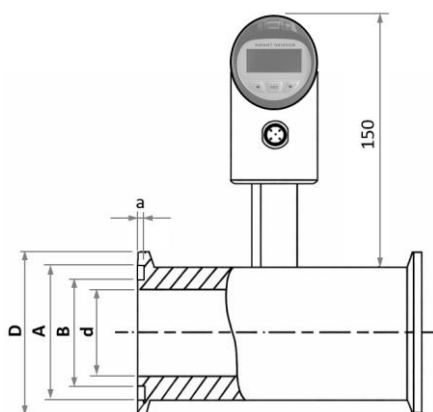

a	DN4~DN40	1mm
	DN50~DN80	1.5mm
	DN100	2mm

Nominal Diameter	D (mm)	A (mm)	B (mm)	d (mm)	L (mm)			
DN4	50.5	46	40.5	4	100			
DN6				6				
DN10				10				
DN15				15				
DN20				20				
DN25				25				
DN32	64	59	53.5	32	120			
DN40				40	140			
DN50				78	73.5	68	50	150
DN65				91	86	80.5	65	170
DN80	106	100.5	94	80	200			
DN100	119	113	106	100	220			

※ Dimension D Indicates the Matching Inner Diameter of the Clamp

Sensor Installation Methods

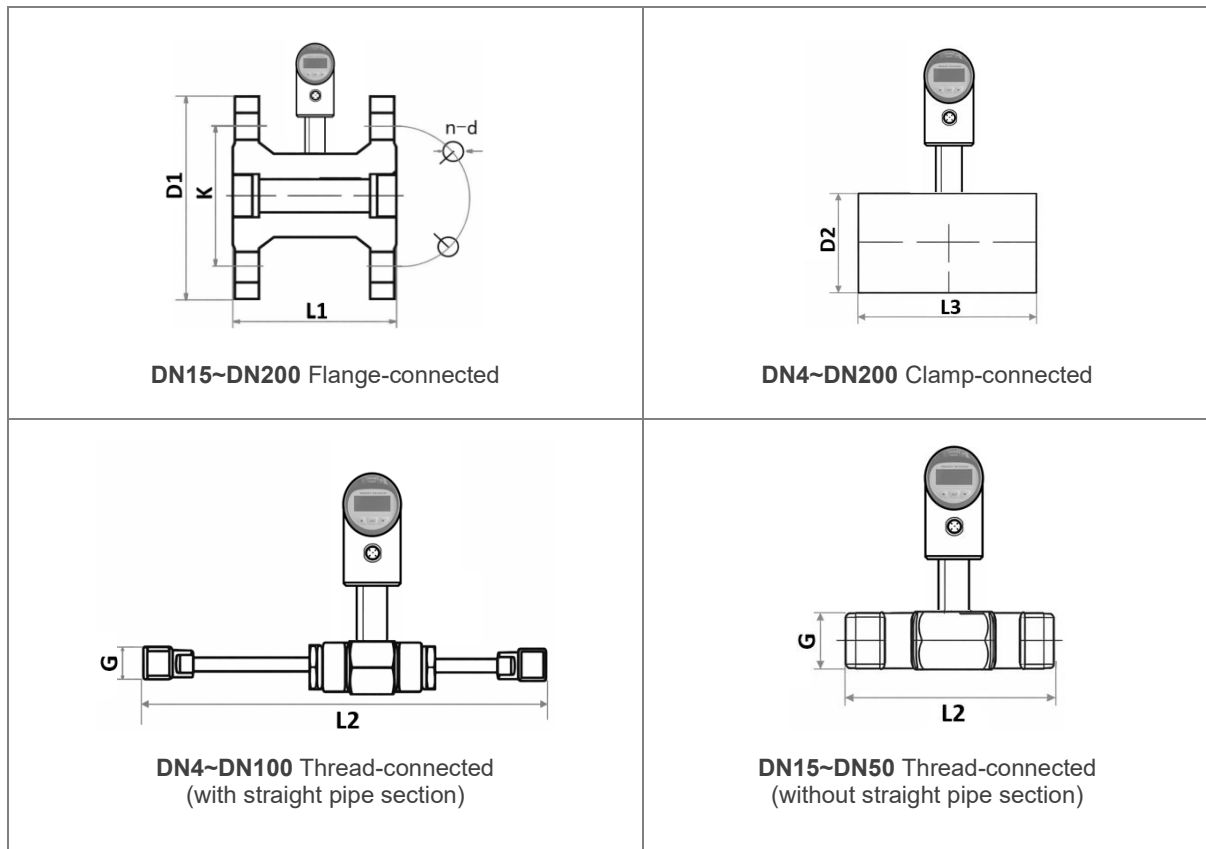

Nominal Diameter (mm)	Flange Connection					Thread Connection		Clamp Connection	
	L1 (mm)	D1 (mm)	K (mm)	d (mm)	n (Holes)	L2 (mm)	G (External Thread)	L3 (mm)	D2 (mm)
4						225	G1/2	50	38
6						225	G1/2	50	38
10						345	G1/2	50	38
15	75	95	65	14	4	75	G1	55	47
20	80	105	75	14	4	80	G1	60	54
25	100	115	85	14	4	100	G5/4	60	57
32	140	140	100	14	4	140	G2	70	66
40	140	150	110	18	4	140	G2	70	72
50	150	165	125	18	4	150	G5/2	70	92
65	170	185	145	18	4			80	100
80	200	200	160	18	8			90	112
100	220	220	180	18	8			100	137
125	250	250	210	18	8			120	165
150	300	285	240	22	8			150	190
200	360	340	295	22	12	150	243		

4-3. Installation Instructions

To ensure measurement accuracy of the **GTR-Micro Turbine Flow meter** and minimize interference from disturbed flow and air bubbles, the following requirements apply to upstream/downstream straight pipe sections:

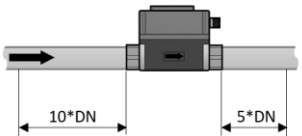
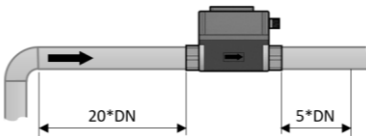
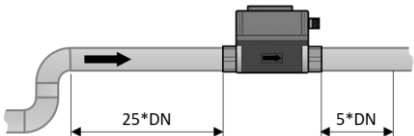
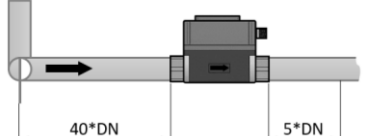
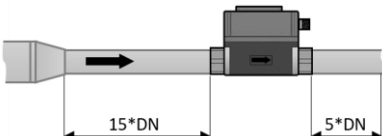
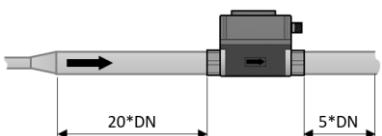
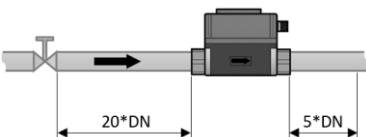
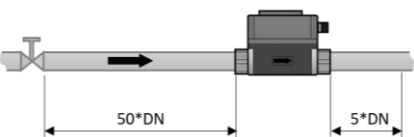
Inlet Section Flow Restrictors Type	Installation Requirements		Inlet Section Flow Restrictors Type	Installation Requirements	
	Inlet Section	Outlet Section		Inlet Section	Outlet Section
General Case			90° Elbow		
Two 90° Elbows in the Same Plane			Two 90° Elbows in Different Plane		
Pipe Reducer			Pipe Expander		
Fully Open Valve			Fully Open Valve		

Notes:

The dimensions shown are the straight pipe installation lengths required to ensure accuracy requirements. If the straight pipe length is doubled, measurement precision can be improved.

- **Upstream:** The dimensions shown are the straight pipe installation lengths required to ensure accuracy requirements. If the straight pipe length is doubled, measurement precision can be improved.
- **Downstream:** The minimum allowed straight pipe length must be at least 5 times the pipe diameter. For example, for a DN50 flow sensor, the downstream straight pipe length must be at least 250 mm, while the optimal downstream length should be 500 mm.

- **The pipeline must be entirely filled with liquid.**

It is critical that the pipe remains completely filled with liquid at all times; otherwise, the flow rate display may be affected, potentially leading to measurement errors.

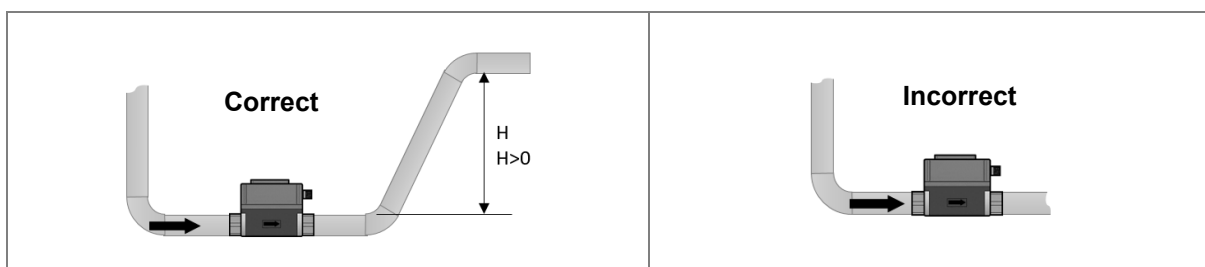

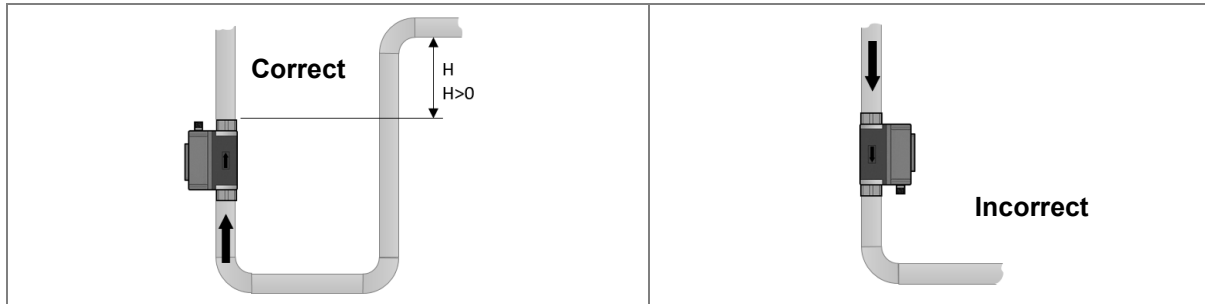

● **Avoid air bubbles.**

If air bubbles enter the measurement pipe, the flow rate display may be compromised, which could result in measurement inaccuracies.

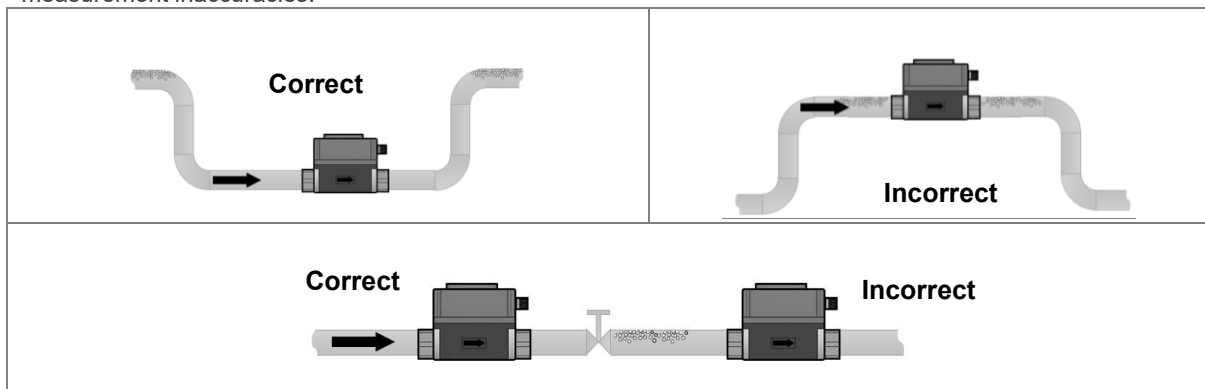

● **Installation location and requirements**

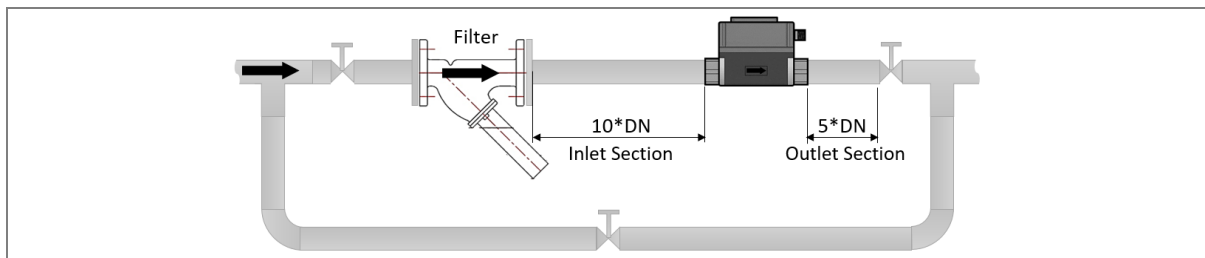

4-4. Pipeline installation precautions

- Sensors should be installed in locations that facilitate maintenance, and must be free from pipeline vibration, strong electromagnetic interference, and thermal radiation effects.
- Horizontal installation: Pipeline inclination should not exceed 5°. Vertical installation: Vertical deviation should be ≤5°. For non-interruptible flow applications: Install a bypass pipe and shut-off valve; ensure zero leakage in the bypass pipe during measurement.
- Before formal sensor installation in new pipelines: Temporarily connect a short pipe section at the sensor position. Install the sensor only after confirming complete pipeline cleaning. For fluids with impurities: Install a filter upstream of the sensor; regularly clean and discharge settled impurities.
- For gas-containing liquids: Install a gas eliminator upstream; outlets of filters/ gas eliminators must be directed to safe areas.
- When installed outdoors: Implement measures to avoid direct sunlight exposure and prevent rain ingress.

4-5. Wiring Instructions

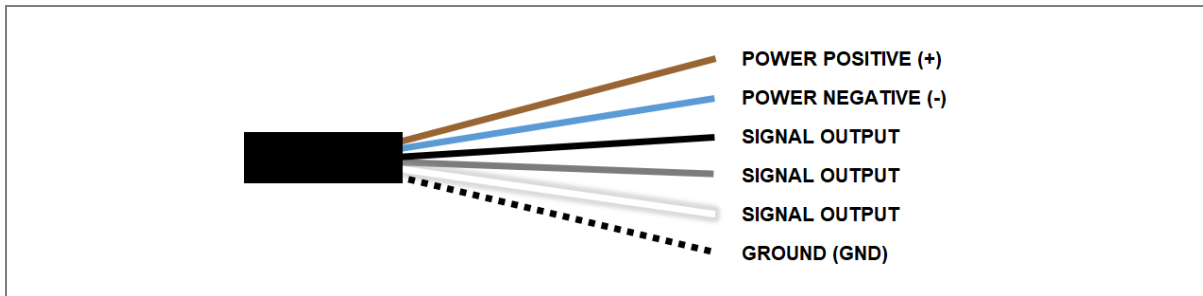

Power Connection: Brown (BN) for Positive (+) and Blue (BU) for Negative (-) power supply
Signal Outputs: Configure Flow/Temperature Alarms and 4-20mA outputs via Black (BK), Gray (GY), and White (WH) wires
Shielded Cable: Aviation-grade shielding design to minimize electromagnetic interference (EMI)

►Wiring Instructions

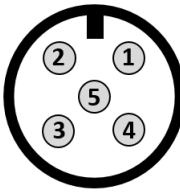

Users can configure the output types of OUT1, OUT2, OUT3 with four options:

1. Flow Alarm
2. Temperature Alarm
3. Flow 4-20mA Output
4. Temperature 4-20mA Output

Aviation Connector

4-20mA, NPN/ PNP Output Wiring Diagram

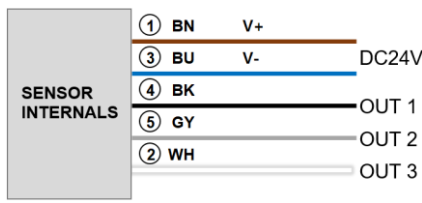

①	Brown(BN)	Positive (+) Power Supply / V+ (DC24V)
③	Blue(BU)	Negative (-) Power Supply / V-
④ (OUT1)	Black(BK)	Flow Alarm Switch Signal, Temp Alarm Switch Signal, Flow: 4-20mA Output, Temp...: 4-20mA Output
⑤ (OUT2)	Gray(GY)	Flow Alarm Switch Signal, Temp Alarm Switch Signal
② (OUT3)	White(WH)	Flow Alarm Switch Signal, Temp Alarm Switch Signal, Flow: 4-20mA Output, Temp...: 4-20mA Output

► PNP Output

Channel 1: 4-20mA Current,
 Channel 1: PNP Alarm Output,
 Channel 2: PNP Alarm Output

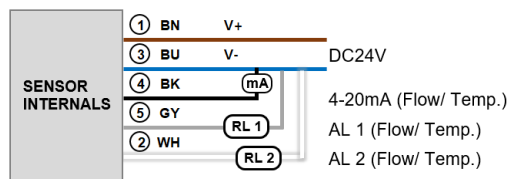

► NPN Output

Channel 1: 4-20mA Current,
 Channel 1: NPN Alarm Output,
 Channel 2: NPN Alarm Output

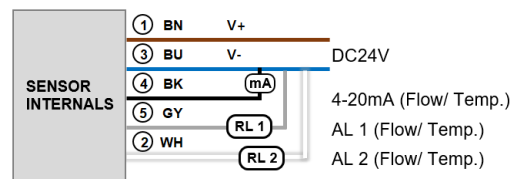

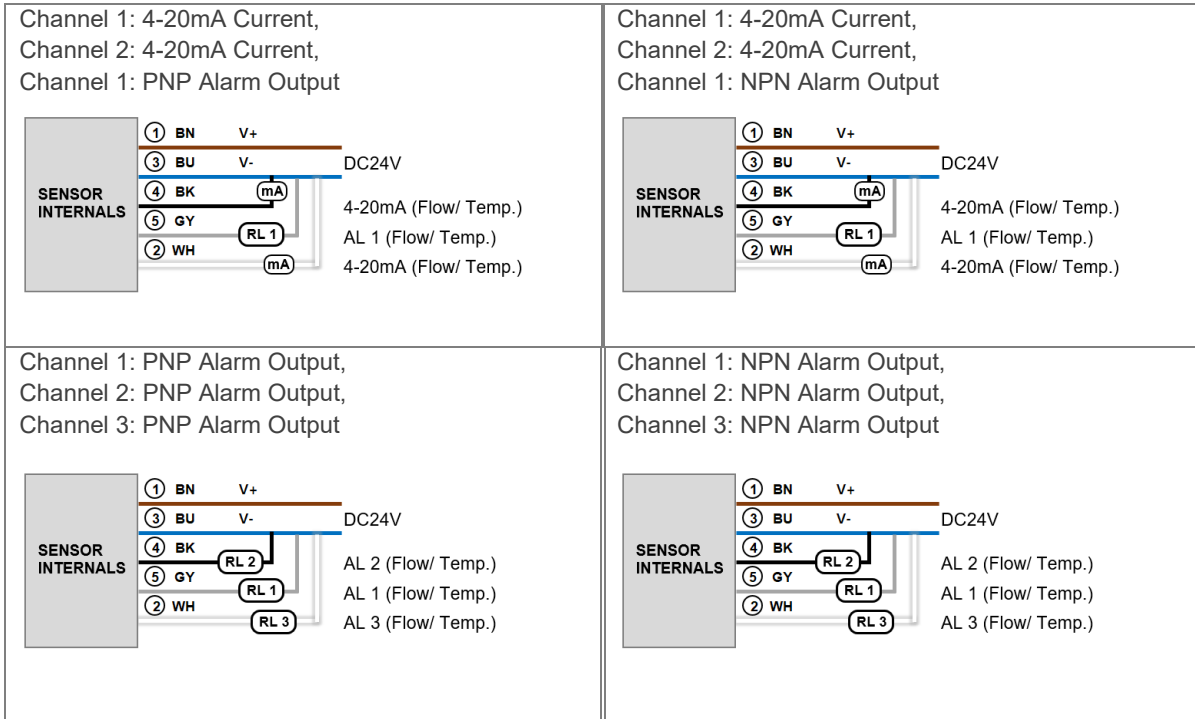

► RS485 Communication output

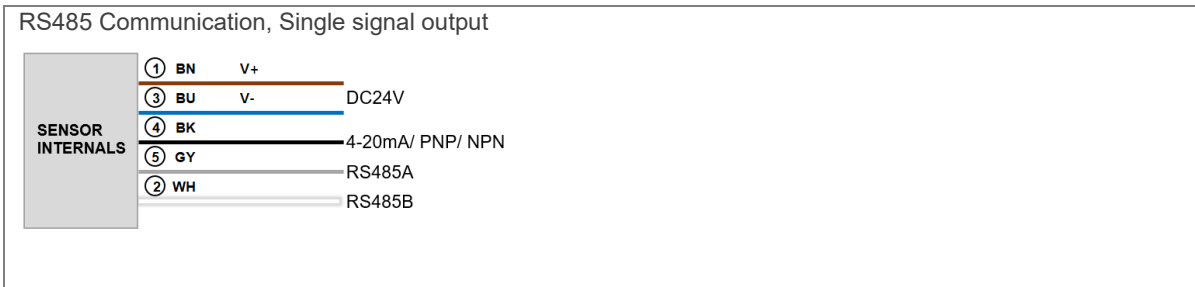

5. Ordering model selection

Code		Description
Model: GTG		Mini Turbine Flowmeter
Installation	N	Internal Thread Installation (DN4~DN15)
	W	External Thread Installation (DN4~DN50)
	F	Flange Installation (DN15~DN200)
	S	Sanitary Clamp Installation (DN4~DN100)
Flow Output	I	4-20mA Output
	M	Pulse Signal
Flow/temperature alarm	P	3-wire DC PNP Output
	N	3-wire DC NPN Output