

Electromagnetic Flow meter

GT300-E series

Electrode easy cleaning by Scraper in option.
Welcome your OEM/ODM regardless of MOQ.



Features:

- No Moving parts, Virtually No pressure loss, Strong durability.
- Various measuring pipe from 6mm to 2400mm.
- Wide measuring range: 0.2~12m/sec. Extra 0.1~15m/sec
- 3 electrodes for measurement and ground are our STD.
- Corrosion protection, Abrasion resistant.
- High accuracy, Stable performance: Standard 0.5% of rate (Option: 0.2~0.3% of rate).
- High level of anti-vibration and anti-jamming, wide measuring dimensions.
- Multi-Output Interface: 4~20mA, Pulse, Alarm Outputs,
- RS-485 and Modbus Communication. GPRS/CDMA.
- Free test software for RS485-Modbus, Profibus.



Greentech Korea Co., Ltd.

Tel: 82.53.762.6668 Fax: 82.53.355.7295

E-mail: gtcinfo@naver.com

Index

- 1. Introduction 1
- 2. Structure and Operation Principle 1
- 3. Technical Specification 2
- 4. Flow Ranges and Flow rate Monograph 3
- 5. Specifications of Signal Converters 4
- 6. Dimensions of Meter and Connection 7
- 7. Ordering Code8

Introduction

These electromagnetic flow meters follow the Faraday law of electromagnetic induction.

They can be used to accurately measure the flow rate of liquids which are electrical conducting, caustic, and mixed with liquids and solids.

They are widely used throughout industries of petroleum, chemical engineering, pharmacology, papermaking, electric power, environmental protection and so forth.



Product actual photos

Structure and Operation Principle

1. Structure

The electromagnetic flow meters are made up of sensor and transducer, together with LCD screen, current and pulse output, alarm signal and RS-485 communication.

2. Operating Principle

Faraday's Laws of Induction form the basis for the electromagnetic flow meters. It states that a voltage is induced in a conductor as it moves through a magnetic field. This principle is applied to a conductive fluid which flows through a magnetic field generated perpendicular to the flow direction (see Schematic). The voltage induced in the fluid is measured at two electrodes, installed diametrically opposed.

This signal voltage U_E is proportional to the magnetic induction B , the electrode spacing D and the average flow velocity v . Noting that the magnetic induction B and the electrode spacing D are constants, proportionality exists between the signal voltage U_E and the average flow velocity v .

The equation for the volume flow shows that the signal voltage U_E is linear and proportional to the volume flow rate.

The induced signal voltage is processed in the converter into scaled, analog and digital signals.

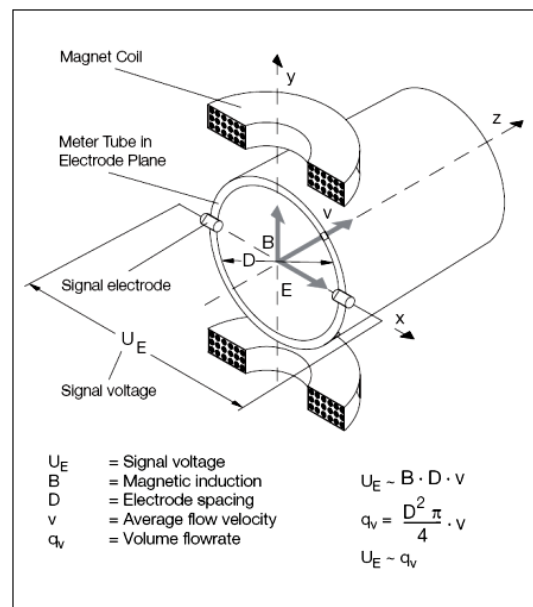

Electromagnetic Flow meter Schematic

Technical Specification

GT300-E Electromagnetic Flow meter					
		Integrated type.		Remote separate type.	
Accuracy		Standard 0.5% of Rate (Span: 0.5~12m/s) Option: 0.2~0.3% of Rate (Span: 0.5~7m/s) (Less than DN300)			
Repeatability		±0.15%.			
Electrode Q'ty		3pcs.			
Min. Conductivity		5 Micro Siemens.			
Measuring range		0.2~12m/sec, Extra 0.1~15m/sec			
Flow direction		Bi-direction.			
Diameter (mm)		DN6~2,400mm.			
Medium Pressure		DN10~1000: 1.0 1.6 2.5 4.0MPa. Please consult with us if you order special pressure.			
Medium Temperature		-40 ~ +200°C			
Material	Body	Steel painted, Stainless steel.			
	Electrode	SUS316L, Titanium, Tantalum, Hastelloy, Tungsten Carbide, Platinum-Iridium.			
	Flux Measuring Tube	SUS304.			
	Lining	Chloroprene Rubber, PTFE, FEP, PFA, Polyurethane, Ceramic.			
	Flange	Standard material: Steel Standard norm.: JIS		Option: SUS304, SUS316, Others. Option: DIN, ANSI, Others.	
Meter Protection Level		IP65, IP67 (Remote type), IP68 (Remote type)			
Ambient Temperature		-25~60°C.			
Influence of Ambient Temperature		< ±0.1% / 10°C or < ±0.25% / 10°C.			
Repetition		≤ ±0.15%.			
Measurement Range of Velocity		≤12m/s.			
Transmitting Signal Converter		Power: 85~240VAC, 50~60hz (Option: DC 20~36V).			
		Output: Standard output (4~20mA and 0~10mA DC), Dual current output, RS485 Option: RS232, HART, Profibus-PA.			
		Analog output error: ≤ ±0.02mA.			
		Display: LCD-Flow rate (4-digits), Totalizer (9-digits), Velocity, Alarm status. Rate: selectable of m³/h, L/sec, US Gal/min, user's). Volume: m³, liter, US Gal, user's Positive, Total, Negative and Auxiliary (clearable, daily) volume.			
		Control: Key board.			
		Time constant: programmable from 1 to 20sec.			
		Mounting: integral or separate,			
		Power consumption: below 20VA.			
		Enclosure: weather proof IP65/IP66.			
		Electric Connections		Standard: 1/2" NPT Option: M20×1.5, PG13.5 (Plastic)	

Remarks: Meter body and Converter housing color may be changed without any prior notice.
The signal converter design and construction may be changed by order specification

Flow Ranges and Flow rate Monograph

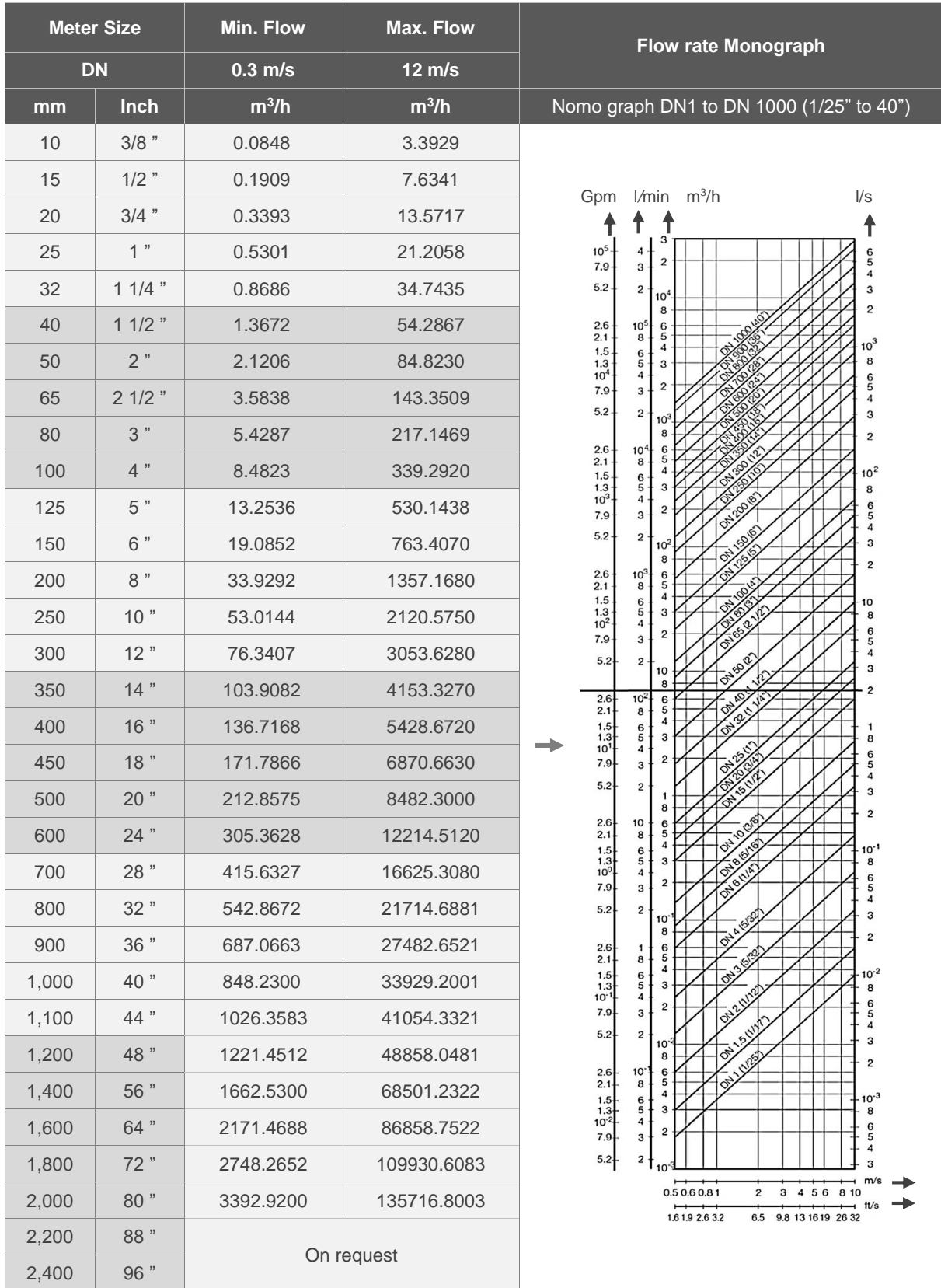

Signal Converters

1. Integral direct mounting: **S400**



- Matched Size: **DN6~2,400mm**
- Power Supply: **85~240VAC, 11~40VDC.**
- Accuracy: **0.5% of rate (Span: 0.3~12m/s),**
Option: 0.2-0.3% of rate (Span: 0.5~7m/s), (Less than DN300)
- Exciting current: **250mA**
- Menu Language: **English**
- Display: **Forward and Reverse Flow rate, Total Flow, Velocity**
- Alarm Function: **Empty Pipe Alarm, System Alarm**
- Signal Output: **Pulse, Frequency, 4-20mA**
- Communication: **RS-485 (Modbus)**
- Enclosure: **IP65/ IP66**
- Style: Single housing/ Double housing

(D) Double housing

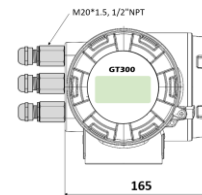
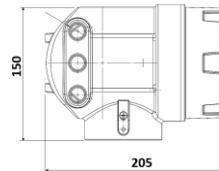

2. Remote mounting – Surface type: **R400-R(S)**



- Matched Size: **DN6~2,400mm**
- Power Supply: **85~240VAC, 20~36VDC.**
- Accuracy: **0.5% of rate (Span: 0.3~12m/s),**
Option: 0.2-0.3% of rate (Span: 0.5~7m/s), (Less than DN300)
- Exciting current: **187mA**
- Menu Language: **English**
- Display: **Forward and Reverse Flow rate, Total flow, Velocity**
- Alarm Function: **Empty Pipe Alarm, System Alarm**
- Signal Output: **Pulse, Frequency, 4-20mA**
- Communication: **RS-485 (Modbus), HART, Profibus**
- Enclosure: **IP65**

3. 2" Pipe mounting – R400-R(P)



- Matched Size: **DN6~2,400mm**
- Power Supply: **85-240VAC**
- Accuracy: **0.5% of rate**
Option: 0.2-0.3% of rate, (Less than DN300)
- Exciting current: **11-12VDC**
- Menu Language: **English**
- Display: **Forward and Reverse Flow rate, Total flow, Velocity**
- Alarm Function: **Empty Pipe Alarm, System Alarm**
- Signal Output: **Pulse, Frequency, 4-20mA**
- Communication: **RS-485 (Modbus), HART, Profibus**
- Enclosure: **IP65**

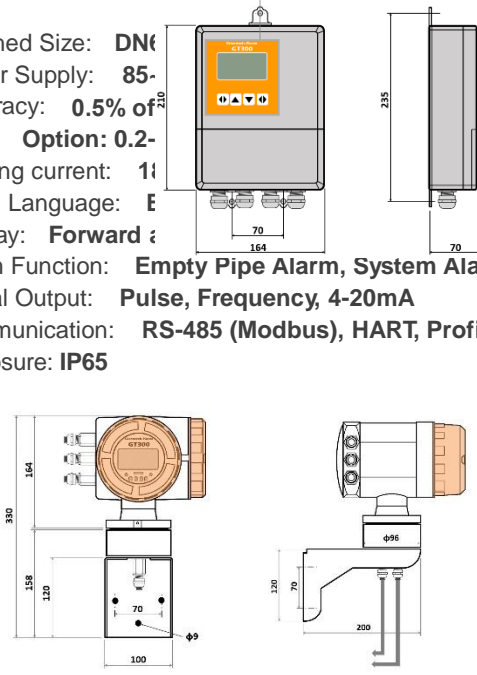

4. Battery type Signal Converter:

A) Battery type: **BT800**



- Matched Size: **DN6~2,400mm**
- Power Supply: **Battery Supply**
- Accuracy: **0.5% of rate (Span: 0.3~12m/s)**,
Option: 0.2-0.3% of rate (Span: 0.5~7m/s), (Less than DN300)
- Battery Lifetime: **3~5 years**
- Display: **Forward and Reverse Flow rate, Total flow, Velocity**
- Alarm Function: **Empty Pipe Alarm, Battery Volume Alarm**
- Signal Output: **RS485 only for calibrating**
- Enclosure: **IP68**
- **Direct or remote surface mounting.**

B) Battery type: **BT801**



- Matched Size: **DN6~2,400mm**
- Power Supply: **Battery Supply**
- Accuracy: **0.5% of rate (Span: 0.3~12m/s)**,
Option: 0.2-0.3% of rate (Span: 0.5~7m/s), (Less than DN300)
- Battery Lifetime: **3~5 years**
- Display: **Forward and Reverse Flow rate, Total flow, Velocity**
- Alarm Function: **Empty Pipe Alarm, Battery Volume Alarm**
- Signal Output: **RS485 only for calibrating**
- Enclosure: **IP65**
- **Remote surface mounting.**

C) Battery type with GPRS/CDMA communication faction: **BT803**



- Matched Size: **DN6~2,400mm**
- Power Supply: **Battery Supply and AC power**
- Accuracy: **0.5% of rate (Span: 0.3~12m/s),**
Option: 0.2-0.3% of rate (Span: 0.5~7m/s), (Less than DN300)
- Battery Lifetime: **3~5 years**
- Display: **Forward and Reverse Flow rate, Total flow, Velocity**
- Alarm Function: **Empty Pipe Alarm, Battery Volume Alarm**
- Signal Output: **RS485 only for calibrating**
- Data logger function.
- Communication: **GPRS/CDMA**
- Enclosure: **IP68**
- **Direct or remote surface mounting.**

4. BTU Signal Converter:

- **Two integrators insides to record flow and heat**
- Low frequency square wave excitation, excitation frequency: 1/10 Power frequency, 1/12 Power frequency.
- Exciting Current: **125mA, 250mA**
- Empty pipe measuring with no additional pole, continuously measuring and alarm by fixed value
- Flow velocity measuring range: **0.1 to15m/s**, velocity resolution: **0.5mm/s**
- AC high-frequency switching power supply: **85VAC to 250VAC**
- 24V DC switching power supply: **20VDC to 36VDC**
- Network function: **MODBUS, Option: HART, GPRS, PROFIBUS**
- 3 button operation
- **Temperature sensor:**
3 wire PT100 insertion type
Measuring temperature range: -30 ~ +160°C
Easy installation without stop production
Measure accuracy: 100°C, ±0.8°C

Integral direct mounting type



Remote – Surface mounting type



BTU Signal Converter: 3 button operation

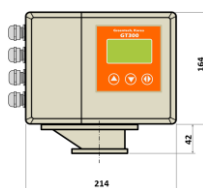

BTU Signal Converter: 3 button operation

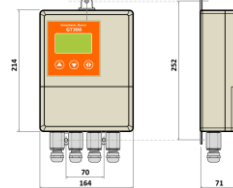

5. Special converter for slurry:

- (1) High excitation frequency of 75Hz, enabling rapid excitation and fast sampling to collect a large volume of flow data.
- (2) Software algorithms. Utilize specialized software algorithms to analyze and process large volumes of traffic data, extracting and recovering genuine traffic signals from low signal-to-noise ratio and high-noise traffic data.

Dimensions of Meter and Connection

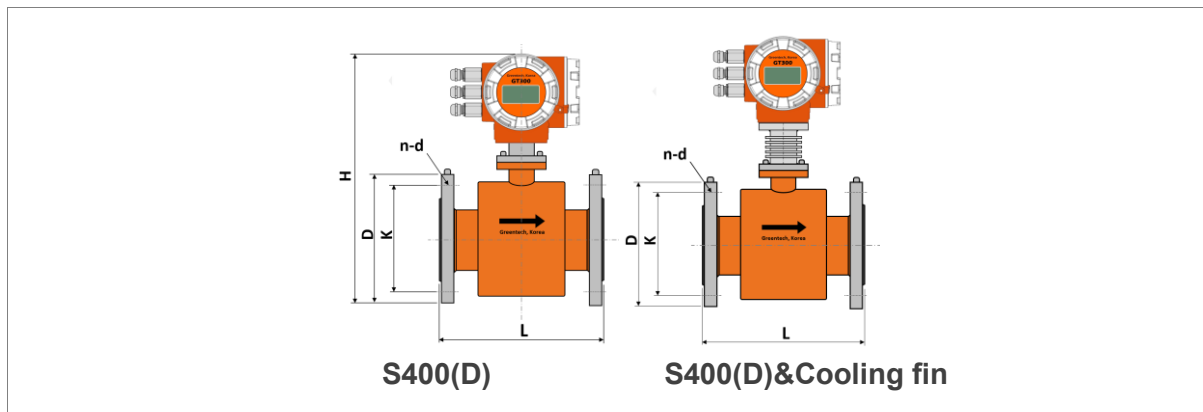

DN		PN MPa	Dimension (mm) Flange			Weight (Kg)			
Inch	mm		L		H				
			PTFE	Rubber	Ø D	Ø K	n- Ød		
3/8"	10	1.6	160	-	Pls refer to flange norm. and size.			225	5
1/2"	15		160	-				245	5
3/4"	20		200	-				260	6
1"	25		200	-				260	6.5
1 1/4"	32		200	-				270	7.5
1 1/2"	40		200	-				275	8.5
2"	50		200	-				290	10
2 1/2"	65		200	200				310	13
3"	80		250	250				320	15
4"	100		250	250				340	16
5"	125		250	250				360	21
6"	150		300	300				400	27
8"	200		350	350				445	35
10"	250		400	400				515	48
12"	300		400	400				565	62
14"	350	400	400	620	73				
16"	400	1.0	450	450	675	79			
18"	450		-	450	710	87			
20"	500		-	450	770	100			
24"	600		-	600	880	180			
28"	700		-	700	960	250			
30"	800		-	800	1055	300			

Ordering Code.

1. Selection codes of Flow meter

Code: GT300-E- □ - □ - □ - □ - □		Description
Meter Style	F	General flange connection (DN6~2,400mm)
	T	Thread connection version (DN25~100mm)
	TR	Tri-clamp connection (DN25~10mm)
	HP	High pressure version (DN10~200mm)
	W	Wafer connection (DN25~200mm)
Meter size	-XXX	DN6. 10. 15. 20. 25. 32. 40. 50. 65. 80. 100.....2,400mm
Flow sensor Housing material	CS	Carbon steel with painted
	S ()	(04): SUS304, (16): SUS316 (DN10~200mm)
Electrodes Material	L	SUS316L
	T	SUS316TI
	TI	Titanium
	TA	Tantalum
	HB	Hastelloy B
	HC	Hastelloy C
	ST	Stainless coating tungsten carbide.
	PT	Platinum-Iridium
	Option: Scraper	N: No Y: For electrode cleaning/ More than DN100
Lining Material	R	Chloroprene Rubber (DN125~2,400mm)
	E	EPDM
	F	FEP (DN10~500mm)
	T	PTFE
	V	PVDF
	PA	PFA
	U	Polyurethane
	C	Alumina ceramic
Connection flange Material	C	Carbon steel Flange
	S ()	Stainless steel Flange (04): SUS304, (16): SUS316
Process Connection Norm. & size	-D ()	DIN PN 0.6, 1.0, 1.6, 2.0, 2.5, 4.0MPa
	-A ()	ANSI CL150, CL300, CL600
	-J ()	JIS 10K, 20K, 30K, 40K
	O	Others
Liquid temperature	L	<60°C: Chloroprene Rubber: <80°C EPDM
	T	<120°C: PTFE, FEP, PFA, Polyurethane, Ceramic
	E ()	Integral type with cooling fin (F): FEP Lining: Less than 150°C (P): PFA Lining: Less than 200°C
	H	<180°C: Remote type
Flow sensor protection Class	A	IP65
	B	IP67 (Remote version only)
	C	IP68 (Remote version only)

2. Selection codes of Signal Converter

Signal converter type	S400()	S	Single housing
		D	Double housing
	S500	For slurry only	
		S	Single housing
		D	Double housing
	R400	Remote type	
	BTU	Magnetic flowmeter for Heat Meter and Cold Meter	
	BT800	Battery type (0.5%)-Direct mounting, RS485	
	BT801	Battery type (0.5%)-Remote surface mounting, RS485	
BT803	Battery type (0.5%)-Direct mounting, RS485 & GPRS. CDMA		
Mounting Construction	-I		Integral direct mounting
	-R ()		Remote mounting – (S): Surface mounting, (P): 2" Pipe mounting
Enclosure	A		IP65
	C		IP68 (BT800, BT803 converter)
Power supply	A		85~240VAC
	B		11~40VDC
	C		Lithium battery (RS485 output only for calibration)
Standard output	-C		4-20mA Current output or 0-10mA Dual current output Pulse output, Frequency output, RS485 MODBUS
	-X		For BT800, BT801, BT803, Battery converter.
Option	-N		No option (in case of battery power, this is right).
	-F		Profibus
	-H		HART
	-G		GPRS
	-A1		Accuracy: 0.2% of F.S. (Less than DN300)
	-A2		Accuracy: 0.3% of F.S. (Less than DN300)
Cable gland	N		1/2" NPT(SUS304)
	M		M20 X 1.5(SUS304)
	G		PG11(Plastic)
Cables length	-N		No cable (Integral type)
	-()		XX meters. (Remote type). (1): Signal cable with connector, (2): Signal cable without connector. Please mark your cable meters here.

Note 1: Users must consider the characteristics of selected wetted parts material and the influence of process fluids. The use of inappropriate materials can result in the leakage of corrosive process fluids and cause injury to personnel and/or damage to plant facilities.

It is also possible that the instrument itself can be damaged and that fragments from the instrument can contaminate the user's process fluids. Be very careful with highly corrosive process fluids such as hydrochloric acid, sulfuric acid, hydrogen sulfide, sodium hypochlorite, and high-temperature steam (150°C [302°F] or above).

Note 2: The color may be changed by your request with MOQ.

The our technical specifications may be revised for update without prior notice