

Liquid Turbine Flow meter

GTLT

Manual



Greentech Korea Co., Ltd.

www.gtc-baruntech.co.kr
www.greentechkor.com

Part 1 Overview

- 1) Lattice LCD display
- 2) Easy operation
- 3) Configure with temperature/pressure sensor. For temperature sensors, Pt100 or Pt1000;
For pressure sensor, gauge pressure sensor or absolute pressure sensor
- 4) Multiple Outputs can be optional: Two-Wire 4-20mA, Three-Wire pulse and Three-Wire equivalent output
- 5) Excellent nonlinearity correction function, greatly improve the appearance of linearity
- 6) Spectral analysis, improve the ability of anti-interference and vibration resistance
- 7) A variety of measuring medium: vapor, liquid, gas and natural gas, etc.
- 8) Low power consumption, a dry cell can maintain at least 3 years
- 9) Automatic switching ability of the working modes: Battery supply, Two-Wire and Three-Wire
- 10) Self-checking function: the rich self-checking information make easy maintenance and debugging
- 11) Independent password setup, the parameters setup, total flow reset and calibration can be set
With different- level passwords, it is convenient for management
- 12) Three-Wire system supports RS485 communication
- 13) The display unit can be selected and user-defined

Part 2 Operation Instruction

2.1 Keypad Operation

The meter is operated by keypad, and there are some parameters need to be set when installing.

There are three keys: **S**, **OK** and **M/R** from left to right.

S is Shift Key, **OK** is Enter/Next Key,
and **M/R** is Modify/Return Key.

(If there are some special functions of keys,
please follow the instruction below the LCD)

When the system is running, pressing **M/R** key can switch
to main screen 2/main screen 3.



2.2 Power on

After powering on, the meter will do self-checking.

If the system is abnormal after self-checking, the meter will display the interface of error self-checking (Details in self-test menu).

1~2 seconds later, the meter will enter the main screen 1 automatically.

If the system is normal, the meter will enter the main screen 1 directly.

The main screen 1 is shown as below:

Main Screen 1:

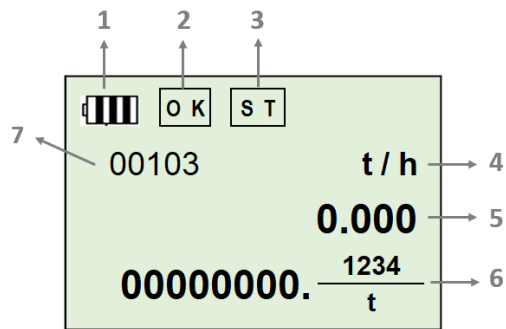

1. **Indicator of running modes:** It displays the battery voltage in battery mode, displays “II” in two-wire current mode, and displays “III” in three-wire mode.
2. **The running status of meter:** If the system of meter is working well, it displays “OK”. Otherwise it displays “ERR”.
3. **Indicator of temperature:** If the system of meter is abnormal or the temperature is manually set, it displays “ST”.
If they are temperature sensors and the temperature sensors are working well, it will be blank.
(The temperature range is -50°C ~ +300°C)
4. **Flow unit:** The instantaneous flow unit.
5. **Flow rate:** The maximum value is 9999 999.
6. **Total flow:**
The maximum value is in 8 bits, and if total flow is more than 8 bits, it will display 9999 9999.
7. **RS485 communication:** The 001 representation for equipment ID, the 03 expressed as RS485 communication mode and the communication baud rate parity.

Main Screen 2:

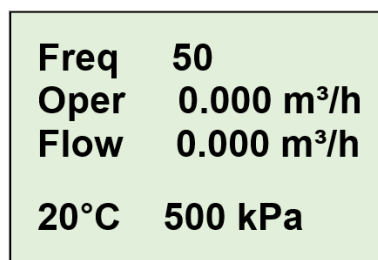

- 50Hz:** Display the running frequency of sensor, the maximum value is 9999.
- Oper 0.000m³/h:** Flow rate in working condition, the maximum value is 9999999.
- Flow 0.000m³/h:** Flow rate in standard condition, the maximum value is 9999999.
- 20°C:** If the internal setting is manually set, it displays the setting temperature.
Otherwise it displays the temperatures which are collected by the temperature sensors on-the-spot.
- 500 kPa:** If the meter is set in manual mode, it displays the setting pressure.
Otherwise it displays the pressure which is collected by pressure sensor on-the-spot.

2.3 Main Menu

-- Main menu --

1. Record query
2. Self-test
3. Total reset
4. Setup
5. Calibration
6. Password
7. Display unit

In the **main screen 1**, **main screen 2** or **main screen 3**,

press **OK** key to enter main menu,

press **S** Shift key to select submenu,

and then press **OK** to enter.

- 1) **Record query**: Query the operation record of meter.
- 2) **Self-test**: Check the running status of meter.
- 3) **Total reset**: Reset total flow.
- 4) **Setup**: Set the operating parameters of meter.
- 5) **Calibration**: Set the parameters of temperature, pressure, current output and flow coefficient.
- 6) **Password**: Modify the passwords of setup, total reset and calibration.
- 7) **Display unit**: Change the display unit of flow, temperature and pressure.

2.4 Record query

Day	record
Month	record
Year	record
Shift	Enter Exit

In Record query menu, users able to view all the operation records by daily, monthly and yearly basis.

Press **S** key to select the option, and press **OK** to enter.

2.5 Self-test

Self-test	
Clock√	Memory√
Power√	AC con√
Param√	Sensor√

If the system of meter is abnormal, enter this menu to check the details of running status, **√** is ok, and **X** means this option is abnormal.

After powering on, the meter will do self-checking.

If there are one or some abnormal options, the meter will display the self-test menu.

When the meter is running, it also can enter this menu to check the running status of meter.

2.6 Total reset

Total flow reset:		
00000000.0000		
Clear	Exit	Clear

In order to prevent unauthorized operation or wrong operation, it needs to input password before total reset.

Input the correct password by **S** Shift key and **M/R** Modify key, and then press **OK** Enter key to enter.

In the total reset menu, it displays the current total flow.

Press **S** and **M/R** key at the same time to reset total flow.

When the LCD displays 00000000.0000, it means that the resetting is successful, press **OK** key to return main menu.

2.7 Setup

In Setup menu, it can set the operation parameters of meter. In order to prevent unauthorized operation or wrong operation, it needs to input password before entering this menu.

After inputting correct password, the LCD will show as below.

Setup menu 1

Language:		
English		
Shift	Next	Rev

Choice of language,
by switching the  key

Setup menu 2

Medium:		
Liquid volume		
Shift	Next	Rev

Select the measuring medium.
It can select the following mediums:
1. Liquid mass (Liquid Mass)
2. Liquid volume (Liquid Volume)

Setup menu 3

Medium Density:		
1000.0000 Kg/m ³		
Shift	Next	Rev

Medium Density.
Set the density of the medium at 20°C.
Please pay attention to the unit of density

Setup menu 4

Expansion Coe:		
0.000000		
Shift	Next	Rev

Coefficient of cubical expansion.
Use this parameter to correct the density of measuring liquid.

Setup menu 5

Low flow cut:		
0000.0000 m ³ /h		
Shift	Next	Rev

Low flow cut off.
When the flow of interference signal is less then this value, the meter will set the flow zero automatically.
This setup can well restrain interference of low frequency.

Setup menu 6

Flow scale:		
000000.00 m ³ /h		
Shift	Next	Rev

Flow range.
Set the maximum flow, and this value is the corresponding value of 20mA when there is 4-20mA output.

Setup menu 7

Damping time: 0		
Shift	Next	Rev

Damping time.
0~9.

Setup menu 8

Band:	0/7
Filter:	0/7
Gain:	12/15
Shift	Next Rev

Frequency band adjustment (Band), Filtering adjustment (Filter) and Gain adjustment (Gain).

Using the three parameters accurately can make the meter working in the best performance (Laypeople shouldn't be permitted to modify this menu).

Setup menu 9

Device ID:	0001
Baud rate:	9600
Parity:	NONE

Set Device ID, Baud rate, Parity of RS485 communication.
Setup menu 10

T input:	Setup
T setup:	+020.0
Normal T:	+020.0
Shift	Next Rev

T input: Collection mode of temperature signal and temperature setup.

The temperature range is -999.9- 999.9, and the unit is °C. If the collection mode is "setup", the meter will correct the flow by setting temperature.

T setup: Temperature setup. There are two collection modes of temperature signal (Temperature sensors and setup). When the temperature of sensor is too large or invalid, the meter calculates the flow with the setting temperature. The default value is 20°C.

Normal T: The temperature in standard condition, operation data when measuring gas.

Setup menu 11

P input:	Setup
P setup:	+00800.0
Atmo P:	101.325
Shift	Next Rev

P input:

Input collection mode of pressure. It can select "setup" or "sensor". If selecting "setup", the meter will compensate the flow with the setting pressure.

P setup: Pressure setup, absolute pressure of operation parameters. Unit is KPa.

Atmo P: Atmosphere pressure. Set as the average atmosphere pressure in local. Use this value to calculate flow. Unit is KPa.

Setup menu 12

High alarm:	
Param:	None
level:	low
Shift	Next Rev

High alarm.

Set the parameter of high alarm and electrical level of alarm output. (HART board doesn't support this function)

Setup menu 13

High alarm:		
+000000.0000		
Hyst:	000.000	
Shift	Next	Rev

High alarm value.

Set the high alarm value and difference value. Difference value is used to prevent alarm vibration around high alarm value. The difference value can make the alarm vibration in control area but reduce the control precision at the same time. Set this value according application and experience.

Setup menu 14

Low alarm:		
Param:	None	
level:	low	
Shift	Next	Rev

Low alarm. Set the parameter of low alarm and electrical level of alarm output.

Setup menu 15

Low alarm:		
+000000.0000		
Hyst:	000.000	
Shift	Next	Rev

Low alarm value. Set the low alarm value and difference value. Refer to high alarm value.

Setup menu 16

Equivalent coe:		
000.0100		
Shift	Next	Rev

Equivalent coefficient.

Equivalent equals to specific or common numerical quantity. This value used to make the flow rate to output equivalent pulse. Unit is m³/p (m³/p is cubic meter per pulse).

Setup menu 17

Clock setup:		
2013-03-28		
08:23:38		
Shift	Exit	Rev

Clock setup.

Display and set current data and time.

2.8 Calibration

Temp channel
Pressure channel
Current output
Flow coefficient

The parameters in this menu are very important. In order to prevent unauthorized operation or wrong operation, it needs to input password before entering this menu.

In this menu, there are four options: Temperature channel, Pressure channel, Current output and Flow coefficient.

Press  Shift key to select options.

T zero:	+0.00	
T coe:	1.000	
Sensor:	Pt100	
Shift	Exit	Rev

Temperature channel: Input correction coefficient and sensor type to correct the temperature which is collected by temperature sensor.

If the collection mode of temperature signal is temperature setup, there is no need to set these parameters.

T Zero: When calculating flow, use the temperature collected by temperature sensor adding T zero.

T coe: Correct the temperature in a multiple. If not, T coe is 1.

Sensor type can select Pt100 or Pt1000.

P zero:	+0.00
P coe:	1.000
P gain:	5/7 AP
Shift	Next Rev

Pressure channel: Input correction coefficient to correct the pressure which is collected by pressure sensor. If the collection mode of pressure signal is pressure setup, there is no need to set these parameters.

P Zero: The calculating pressure is the pressure collected by pressure sensor adding P zero.

P coe: Correct the pressure in a multiple. If not, P coe is 1.

P gain: Amplification factor of signal collected by pressure sensor.

GP: Gauge pressure sensor; **AP:** Absolute pressure sensor.

Press  Next key to enter the second correction of pressure channel.

P coe: sect	0
Std:	00000.0 Kpa
Test:	00000.0 Kpa
Shift	Exit Rev

Second correction of pressure channel: It can correct pressure second time, and there are five sections. It is suitable for application requiring higher pressure accuracy. Std is standard pressure value, and Test is the pressure value measured by sensor.

Equivalent zero:	
20 / 40	
Shift	Exit Rev

Current output: input correction parameter to adjust the zero point of current output.

Note: if modifying this parameter, it will shut off the current output. Therefore, if the current output is in use, please don't modify this parameter

Flow coe: Sect	0
Freq: 5000	
Coe: 000000.0000	
Shift	Next Rev

Flow coefficient:

When setting flow coefficient, it can set by section, the number of sections is 0~9.

Freq: Frequency of section, the input range is 0-9999.

Coe: Flow coefficient corresponding to different section.

After calibration, input the frequency of section and flow coefficient from section 0 to section 9.

Note: If the ten sections are not all in use, for example, there are five sections in use (Section 0 to section 4), set section of frequency 5000 and flow coefficient of section 4 in section 5.

Press  Next key to enter the average flow coefficient.

Average flow coe	
000000.0000	
Shift	Exit Rev

Average flow coefficient: It is used for non-linearity correction. When the coefficients of section close up to the average flow coefficient, then it can reduce the nonlinear error greatly, and improve the accuracy of meter.

2.9 Password

Setup pwd	
Total reset pwd	
Calibration pwd	
Shift	Enter Exit

In this menu, it can modify the password of total reset, setup and calibration.

Enter this menu, press  Shift key select the option which is needed to modify, enter, input the old password, and then input

Setup pwd
Old pwd: 0*****
New pwd: *****
Shift Enter Exit

new password in new password option, press **OK** Enter key.
 If the old password is correct, the LCD will display modification successful, and then enter main screen 1 automatically.
 Otherwise the LCD will display modification failed, and then enter main screen 1 automatically.

2.10 Display unit

Flow unit:	t/h
O.F unit:	m ³ /h
T unit:	°C
P unit:	KPa

Flow: The unit of standard condition. If the medium is liquid mass, the unit can be selected t/h, t/min, kg/h and kg/min. If the medium is liquid volume, the unit can be selected m³/h, m³/min, l/h and l/min.

O.F: The unit of working condition.
 The unit can be selected m³/h, m³/min, l/h and l/min.

T: The unit of temperature.

P: The unit of pressure.

Select the needed unit, and then press **OK** Enter key, the main screen will display with the selected unit.

Display saving:
OFF
Exit Rev

Power-saving mode: In display unit menu, press **OK** to enter the setup of power-saving mode.
 If opening the power save mode, the meter will induction the light through light dependent resistor on LCD to control the meter's display.

Part 3 Electrical Outputs Connection

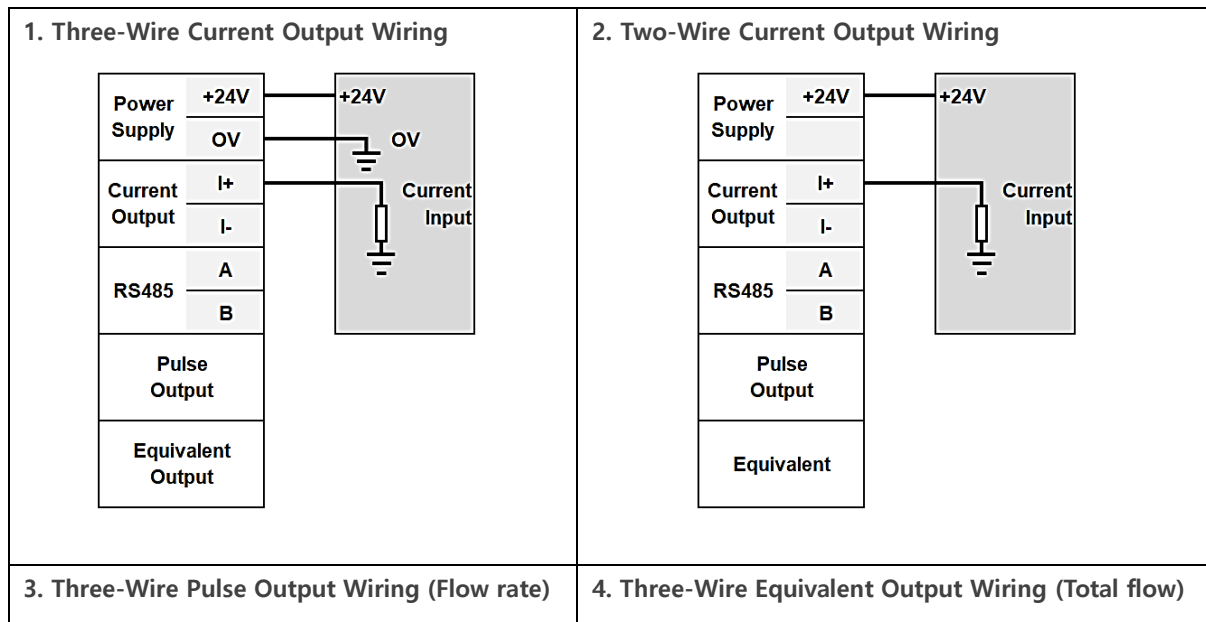

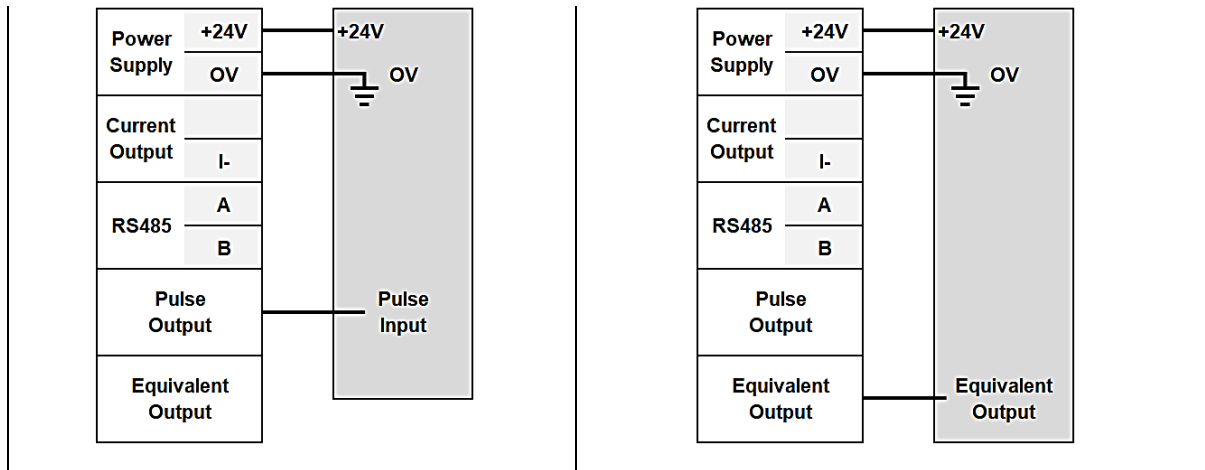

Part 4 Troubleshooting

Fault	Cause	Solution
No output signal after power on	<ol style="list-style-type: none"> No fluid flowing or the flow rate is under starting flow. The connections of power supply and output are incorrect. The pre-amplifier is damaged (The calculator can't count, and the flow rate is 0). The circuit of driving amplifier is damaged (The display of calculator is normal). 	<ol style="list-style-type: none"> Increase the flow rate or replace a flow meter with smaller nominal diameter to meet the requirement of flow range. Make the connection correct. Replace the pre-amplifier. Replace the damaged components in the circuit of driving amplifier.
The meter outputs signal when no flow	<ol style="list-style-type: none"> The interference of bad grounding of meter, strong electricity and interference of other grounding. The higher sensitivity of amplifier or it may produce self-excitation. Unstable power supply, bad filtering or other electrical disturbance. 	<ol style="list-style-type: none"> Make the grounding well Replace the pre-amplifier. Repair or replace the power supply.
Unstable display of flow rate	<ol style="list-style-type: none"> Unstable flow in pipe The higher or lower sensitivity of amplifier make the output pulses are more counted or less counted. There is debris in the shell of meter. Bad grounding. The flow rate is under the low limit. The downstream seal ring reaches into pipe, and make disturbance. 	<ol style="list-style-type: none"> Begin to measure after the flow rate is stable. Replace the pre-amplifier. Remove the debris. Check the grounding, make the grounding well.
The displayed total flow is inconsistent as actual total flow	<ol style="list-style-type: none"> The flow coefficient of meter is incorrect. The flow rate on site is higher than the maximum flow of meter. The bad quality of the flow meter. 	<ol style="list-style-type: none"> Recalibrate the meter and input the new flow coefficient. Reduce the flow rate in pipe or Replace the flow meter. Recalibration

Abnormal display	Bad contact of the key or dead lock the key	Replace the display board.
System halts after replacement new battery	The electrify reset circuit is abnormal, or the oscillating circuit can't afford to boost.	Reinstall the battery (Before reinstall the battery, the meter is needed to discharge more than 5 seconds)