

MU_GT600 Thermal Gas Mass Flowmeter



Greentech Korea Co., Ltd.

www.gtc-baruntech.co.kr
www.greentechkor.com

Contents

1. Introduction	3
2. Features	4
3. Specifications	5
4. Pipe and plug-in structure dimensions	6
4.1 Flange mounting	6
4.2 Card mounted mounting	7
4.3 Plug-in mounting	7
5. Option	8
6. Installation	9
6.1 Cable installation method	9
6.2 Cable installation method	9
7. Operation and Programming	11
7.1 Display	11
7.2 Parameters Setup	11
Appendix 1 Troubleshooting and Repair	15
Appendix 2	16
The density and conversion coefficient of common gas	16
Appendix 3 Upper range value of common gas	18

1. Introduction

Thermal gas mass flow meter is designed on the basis of thermal dispersion, and adopts method of constant differential temperature to measuring gas flow. It has advantages of small size, easy installation, high reliability and high accuracy, etc.

The meter contains two platinum resistance temperature sensors. The thermal principle operates by monitoring the cooling effect of a gas stream as it passes over a heated sensor. Gas flowing through the sensing section passes over two sensors one of which is used conventionally as a temperature sensor, whilst the other is used as a heater. The temperature sensor monitors the actual process values whilst the heater is maintained at a constant differential temperature above this by varying the power consumed by the sensor. The greater the gas velocity, the greater the cooling effect and power required to maintain the differential temperature. The measured heater power is therefore a measure of the gas mass flow rate.

The format of gas velocity and power is shown as below:

$$V = \frac{K[Q/\Delta T]^{1.87}}{\rho_g} \dots\dots\dots (1)$$

Where: ρ_g is specific gravity of medium

V is velocity

K is balance coefficient

Q is heater power

ΔT is differential temperature

The medium temperature range of meter is -40°C ~220°C

In the format (1), the specific gravity of medium is related to the density:

$$\rho = \rho_n \times \frac{101.325 + P}{101.325} \times \frac{273.15 + 20}{273.15 + T} \dots\dots\dots (2)$$

Where:

ρ_g is the medium density in working condition (kg/m³)

ρ_n is the medium density in standard condition, 101.325kPa and 20°C (kg/m³)

P is the pressure in working condition (kPa)

T is the temperature in working condition (°C)

In the formats (1) and (2), there is a certain functional relationship between the velocity and pressure in working condition, medium density, the temperature in working condition.

Due to the sensor temperature is always 30°C higher than the medium temperature (environment temperature), and the meter adopts method of constant differential temperature, therefore the meter do not need to do temperature and pressure compensation in principle.

2. Features

- Thermal gas mass flow meters have the following technical advantages:
- The real mass flow meter does not require temperature and pressure compensation for gas flow measurement, and the measurement is convenient and accurate. A mass flow rate of the gas or a standard volume flow can be obtained.
- Wide range ratio, can measure gas flow rate up to 120Nm/ s down to 0.1Nm/ s, can be used for gas leak detection.
- The seismic performance is good and the service life is long. The sensor has no moving parts and pressure sensing parts and is immune to the influence of vibration on the measurement accuracy.
- Easy to install and maintain. Non-stop production installation and maintenance can be achieved where field conditions permit. (requires special customization)
- Digital design. The overall digital circuit measurement, accurate measurement and convenient maintenance.
- RS-485 communication enables factory automation and integration.
- Oxygen, nitrogen, hydrogen, chlorine and multi-component gas measurements.
- Blast furnace gas, coke oven gas measurement.
- Gas flow measurement of natural gas, liquefied gas, flare gas, etc.
- Primary and secondary air flow measurements of blast furnaces in the power plant.
- Flow measurement of downhole ventilation or exhaust system in Yanzhou Mine.
- Flue gas measurement.
- Compressed air measurement.

3. Specifications

Structure type	Plug-in	Pipeline
Measuring medium	Common steady-state gases (unstable media such as acetylene and boron trichloride are not measurable)	
Pipe size	DN65~DN400mm	DN15~DN2000mm
Velocity	0.1~120 Nm/s	
Accuracy	±1~2.5%	
Operating temperature	Sensor: -40°C ~ +450°C	
	Transmitter: -20°C~ +45°C	
Pressure	Medium pressure ≤4.0MPa (≥4.0MPa Agreement supply)	Medium pressure ≤1.6MPa (≥4.0MPa Agreement supply)
Power	24VDC ≥18W	
Response time	1s	
Output	4-20mA (Optical isolation, Maximum load 500ohm), RS485 (Lightning protection)	
Alarm output	1~2 normally open contacts, 24V/ 0.5A	
Type of supply	Integrated structure	
Pipe material	Carbon steel, Stainless steel, Plastic, Etc	
Live display	Four-line LCD display	
Display content	Mass flow rate, standard volume flow rate, cumulative flow rate, standard flow rate, etc.	
Protection level	IP65, IP67, IP68	
Sensor housing material	Stainless steel	Carbon steel

4. Pipe and plug-in structure dimensions

4.1 Flange mounting

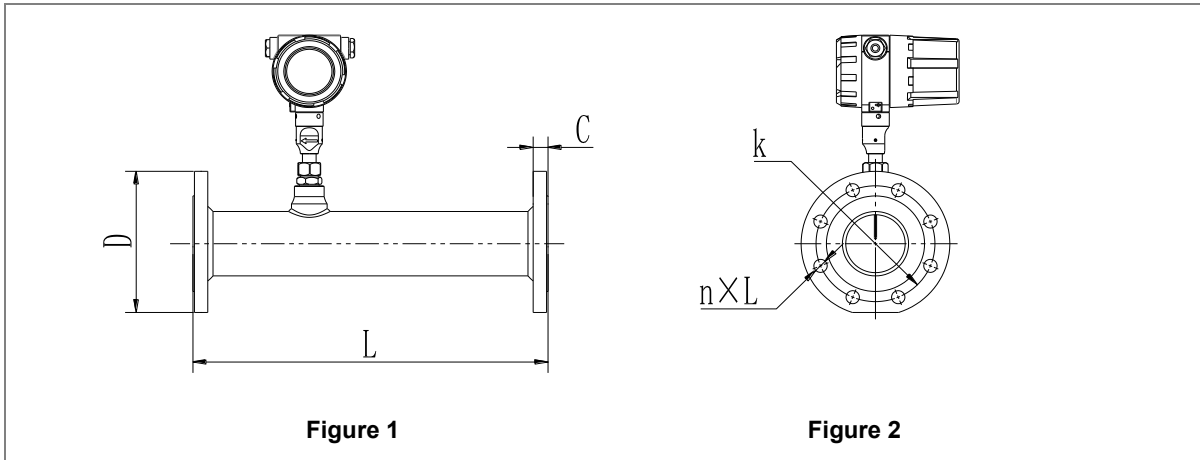

PN1.6Mpa (16bar) Flat, protruding panel flat welded steel pipe flange

Unit: mm

DN	Pipeline Length L	Flange Outer diameter D	Center Hole K	Screw Hole n*L	Screw Thread	Flange thickness C
15	160	95	65	4*14	M12	12
20	160	105	75	4*14	M12	14
25	160	115	85	4*14	M12	14
32	160	140	100	4*18	M16	16
40	180	150	110	4*18	M16	16
50	180	165	125	4*18	M16	18
65	180	185	145	4*18	M16	20
80	180	200	160	8*18	M16	20
100	200	220	180	8*18	M16	20
125	200	250	210	8*18	M16	20
150	200	285	240	8*22	M20	22
200	200	340	295	12*22	M20	22
250	200	405	355	12*26	M24	24
300	200	460	410	12*26	M24	24

4.2 Plug-in mounting

Unit: mm

- (1) The integral plug-in type should be inserted into the axis of the pipe to be tested, so the length of the measuring rod depends on the diameter of the measuring pipe. It should be stated when ordering.
- (2) If it cannot be inserted into the pipe axis, the factory will provide the calibration factor to complete the accurate measurement.

Unit: mm

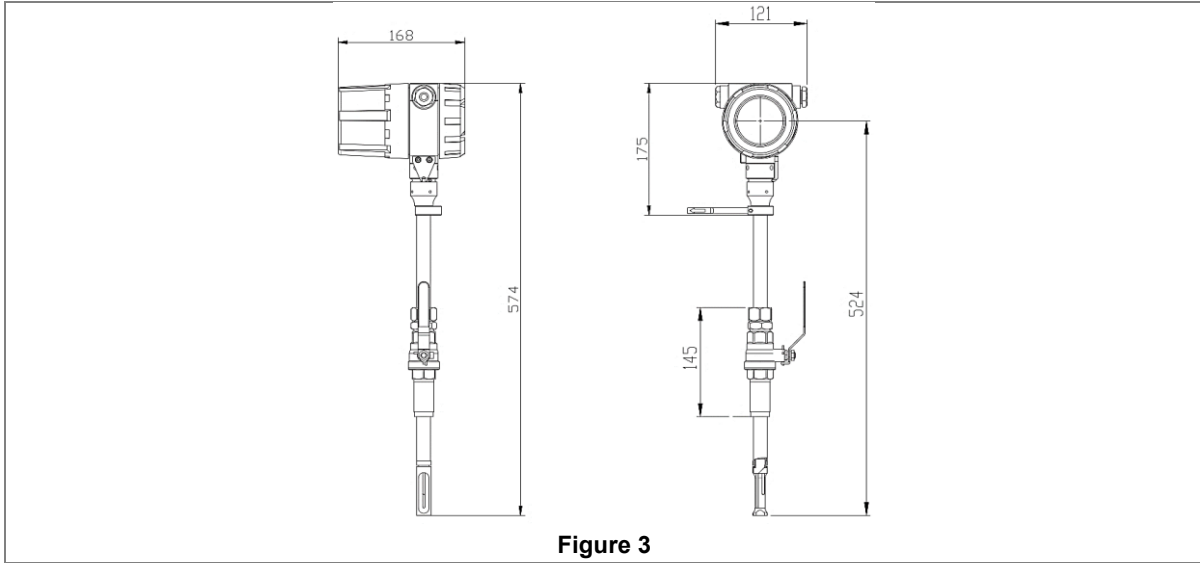

4.3 Wafer mounting

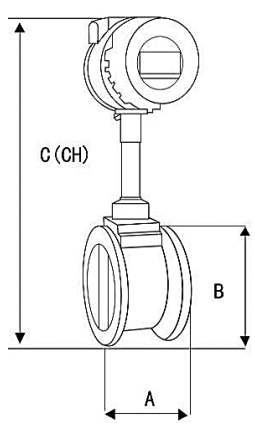
DN	Caliber DN	A	B	C (CH)
 <p style="text-align: center;">Figure 4</p>	15~25	70	55	390 (455)
	32	70	55	390 (455)
	40	85	80	385 (440)
	50	85	90	390 (450)
	65	85	105	400 (470)
	80	85	120	420 (480)
	100	85	140	440 (500)
	125	90	165	465 (530)
	150	100	194	490 (560)
	200	102	248	545 (610)
	250	115	300	595 (650)
	300	130	350	645 (710)

- (1) For DN15 ~ DN80 can be used pipe thread connection.
- (2) Only the maximum rated pressure data of 1.6Mpa is given in the table, and it can be customized above the rated pressure.
- (3) The integral full tube can be flanged, threaded and snap-fit.

5. Option

Thermal gas mass flow meter range table

Size (mm)	Base range (Air) Nm ³ /h	Extended range (Air) Nm ³ /h	Oxygen Base range Nm ³ /h	Combustible gas range Nm ³ /h
10	0.5~28	0.03~30	0.5~14	0.5~5.0
15	0.5~65	0.07~65	0.5~32	0.5~10
20	0.5~100	0.12~110	0.5~55	0.5~20
25	0.5~175	0.18~180	0.5~89	0.5~28
32	0.5~290	0.3~290	0.5~144	0.5~45
40	0.5~450	0.5~450	0.5~226	0.5~70
50	1.0~600	0.5~700	0.7~352	0.7~110
65	1.5~1,000	1.0~1,200	1.2~600	1.2~185
80	2.0~1,500	1.5~1,800	2.0~900	2.0~280
100	3.0~2,300	3.0~2,800	3.0~1,420	3.0~470
125	4.5~3,500	4.0~4,400	4.5~2,210	4.5~700
150	6.5~5,200	6.0~6,300	6.5~3,200	6.5~940
200	12~9,000	12~11,500	12~5,650	12~1,880
250	18~14,500	18~17,500	18~8,830	18~2,820
300	25~21,000	25~25,000	25~12,720	25~4,060
350	35~28,000	35~34,500	35~17,000	35~5,600
400	45~36,500	45~45,000	45~22,600	45~7,200
500	60~46,500	60~57,000	60~29,000	60~9,200
600	70~57,000	70~70,000	70~35,300	70~11,280
700	100~81,000	100~101,000	100~50,600	100~16,300
800	140~110,000	140~138,000	140~69,000	140~22,100
900	180~150,000	180~180,000	180~90,000	180~29,000
1000	230~185,000	230~230,000	230~115,000	230~36,500
2000	290~230,000	290~280,000	290~140,000	290~45,500

Note:

- 1) Determination of the upper and lower limits of the range:
 - A Determination of the lower limit: Since the lower limit of the thermal gas mass flow meter can measure extremely low flow rates, such as 0.1 Nm³/s, it is not necessary to consider the lower limit in the selection.
 - B Determination of the upper limit: Generally, the choice is higher, and there should be more than 20%. Because the actual flow is easy to estimate the error.
 - C Mixing gas range: For mixed gas, the user should give the molar ratio of the standard and the mixed gas (the percentage of each component to the total flow), and then the range is determined by the manufacturer. It is usually calibrated with air and then multiplied by a conversion factor.
 - D Explosion-proof product upper limit: 1) the maximum flow rate is preferably less than 17m/s.
- 2) Standard state flow: flow at a temperature of 20°C and a pressure of 101.325 KPa.
- 3) The unit of instantaneous flow rate can be Nm³/ h, Nm³/ min, L/ h, L/ min, t/ h, t/ min, kg/ h and kg/ min.
- 4) Conversion of working condition flow and standard condition flow:

$$Q_{\text{Standard condition}} = \frac{101.325 + P}{101.325} \times \frac{273.15 + 20}{273.15 + T} Q_{\text{Working condition}}$$

5) Flow rate calculation formula
$$V = Q / (\pi \times (\frac{D}{2} / 1000)^2) / 3600$$

Q Standard condition: Standard state flow (Nm³/h)
Q Working condition: Working condition flow (m³/h)
T: Working medium temperature (°C)
P: Working medium pressure (gauge pressure KPa)

V: medium standard flow rate (Nm/S)
Q: standard state flow (Nm³/h)
D: measuring pipe diameter (mm)



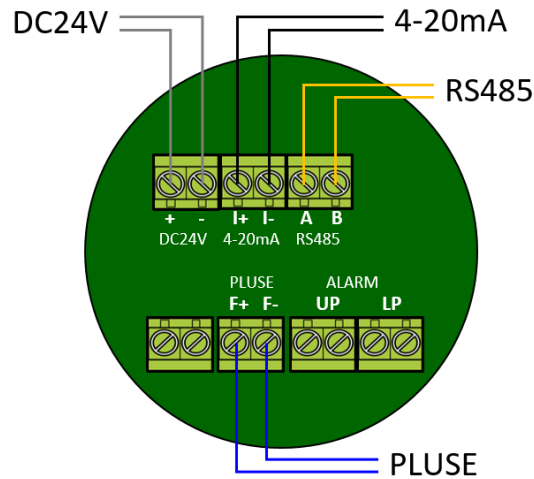

6. Installation

6.1 Cable installation method

Terminal block description and wiring method:



6.2 Cable installation method

-  If the instrument is installed outdoors, the instrument sun shield should be added to avoid sun and rain.
-  Do not install in places subject to strong vibration.
-  Do not expose to an environment containing a large amount of corrosive gases.
-  Do not share the power supply with equipment that pollutes the power supply such as inverters or welders. If necessary, install a clean power supply for the converter.

6.2.1 Installation location and requirements for piping

- (1) When installing the instrument, keep away from elbows, obstacles, reducers, and valves to ensure a stable flow field. On the other side, a long upper straight pipe is required. The front straight pipe length is greater than 10D, and the rear straight pipe length is long. More than 5D. The following figure shows the length of the straight pipe required for several situations that are often encountered in the field:
- (2) When the site can not meet the requirements of the straight pipe section, the gas rectifier can be connected in series to greatly reduce the requirements for the straight pipe section.

1	Horizontal pipe	
2	Bent pipe	
3	Head tube	
4	Downstream of the valve	
5	Shrink tube	
6	Downstream of the pump	

Figure 6 Straight pipe section before and after installation

7. Operation and Programming

7.1 Display The display of meter in working status is shown as below.

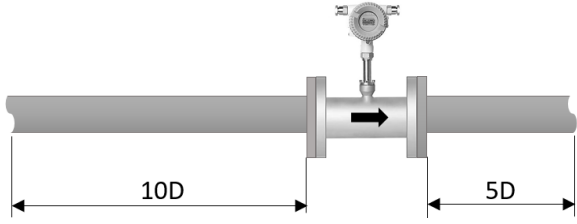
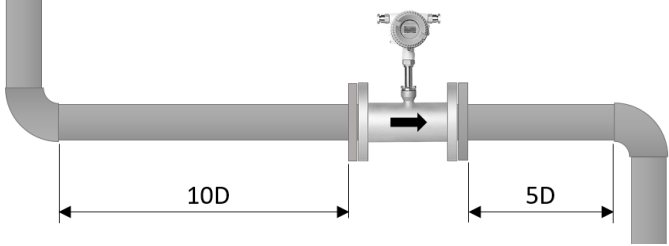
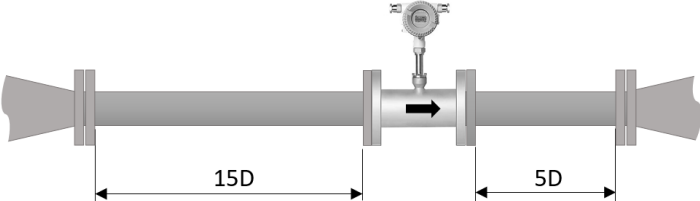
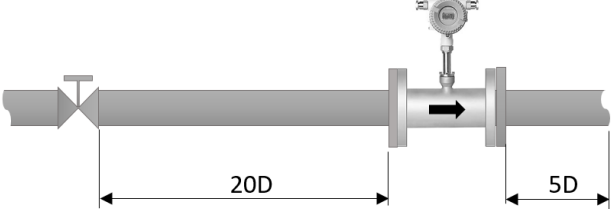
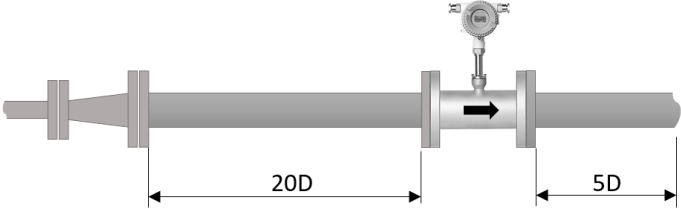
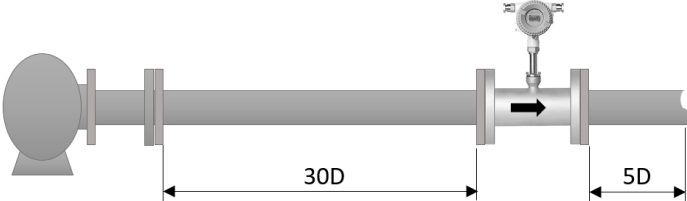
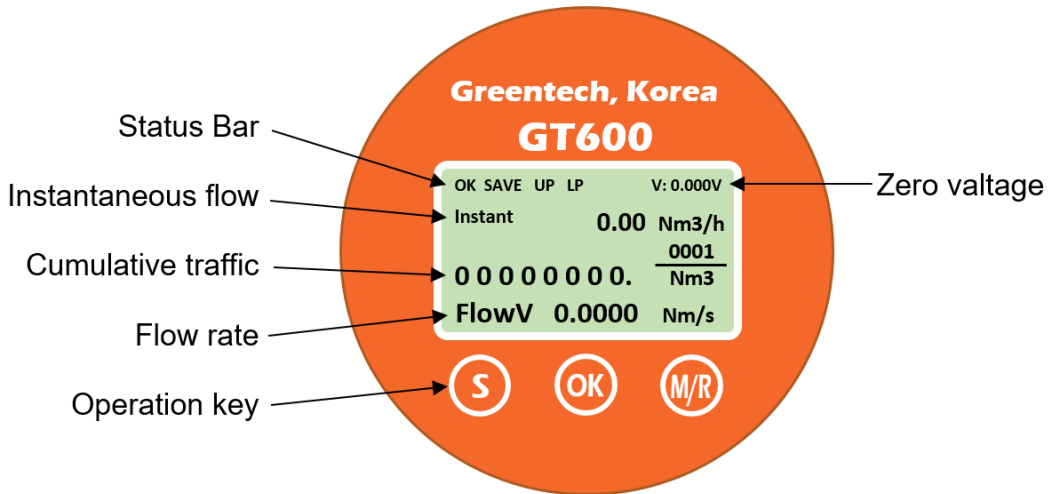

Figure 8

The prompt line:

- (1) When the meter is working normally and power is on, it will perform self-test. When the self-test is normal, it will prompt **OK**, **SAVE**;
- (2) Instrument alarm channel prompt, **UP** indicates the upper limit alarm, **LP** indicates the lower limit alarm.
- (3) The instrument performs parameter setting by pressing the button. Generally, some parameters are set manually by using the button during installation.

The meter has three buttons, from left to right is **S** **OK** **M/R**.

Usually **S** is shift key, **OK** is add key, **M/R** is confirm save and change button, confirm and shift button under password menu, under the password menu **M/R** is the confirmation and shift button.

7.2 Parameters Setup

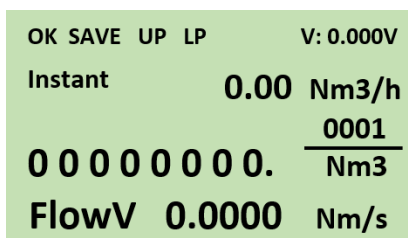

Under this interface, press **S** (Shift) button to enter the setup menu.

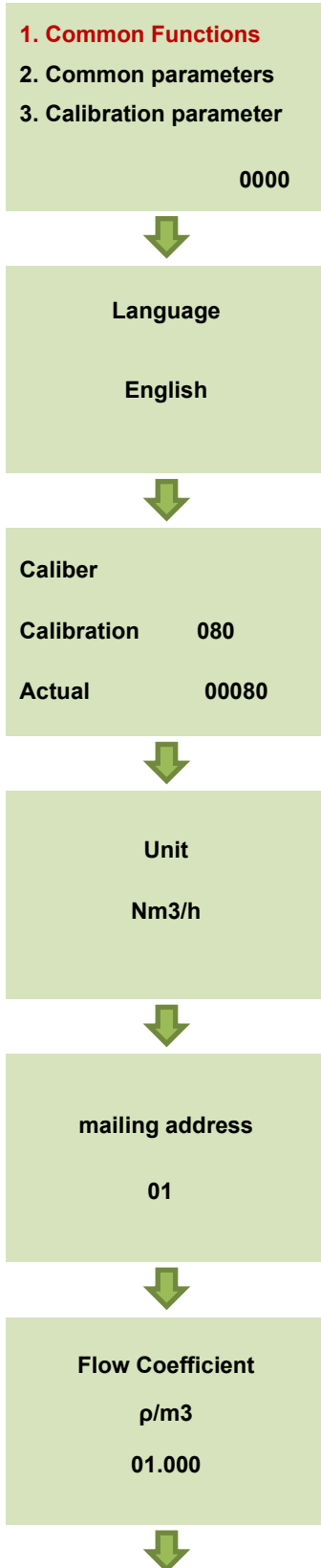

In the main interface, press **S** to enter the main menu interface. You can use the **S** to select the corresponding menu item and press **M/R** to enter.

In the main menu of the main interface, press **M/R** to enter the common menu interface.

Press **M/R** to save and go to the next menu, press **S** to move the cursor position, and **OK** to modify the parameters.

Under the language menu, press **M/R** to save and enter the caliber menu.

Press **M/R** to save and go to the next menu, press **S** to move the cursor position, and **OK** to modify the parameters.

Under the caliber menu, press **M/R** to save and enter the unit menu. Press **M/R** to save and go to the next menu, press **S** to move the cursor position, and **OK** to modify the parameters.

Under the unit menu, press **M/R** to save and enter the communication address menu.

Press **M/R** to save and go to the next menu, press **S** to move the cursor position, and **OK** to modify the parameters.

In the Communication Address menu, press **M/R** to save and enter the flow coefficient menu.

Press **M/R** to save and go to the next menu, press **S** to move the cursor position, and **OK** to modify the parameters.

The coefficient is proportional to the flow rate, which is the total coefficient.

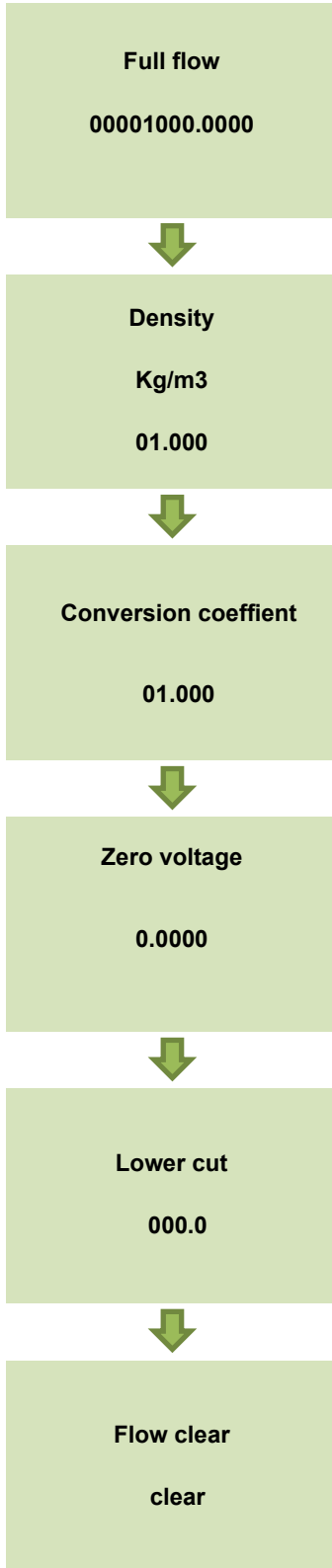

In the Flow Factor menu, press **M/R** to save and enter the full flow menu.

Press **M/R** to save and go to the next menu, press **S** to move the cursor position, and **OK** to modify the parameters.

Under the caliber menu, press **M/R** to save and enter the unit menu.

Press **M/R** to save and go to the next menu, press **S** to move the cursor position, and **OK** to modify the parameters.

Under the density setting menu, press **M/R** to save and enter the conversion factor menu.

Press **M/R** to save and go to the next menu, press **S** to move the cursor position, and **OK** to modify the parameters. Enter the corresponding conversion coefficient value for different media.

Under the Conversion Factor menu, press **M/R** to save and enter the zero voltage menu.

Press **M/R** to save and go to the next menu, press **S** to move the cursor position, and **OK** to modify the parameters. This menu is set to 0 point voltage.

Under the zero voltage menu, press **M/R** to save and enter the lower cut menu.

Press **M/R** to save and go to the next menu, press **S** to move the cursor position, and **OK** to modify the parameters. This menu cuts off the value of the instantaneous flow.

Under the lower cut menu, press **M/R** to save and enter the clear menu. Press **OK** to clear the accumulated flow.

```

OK SAVE UP LP      V: 0.000V
Instant           0.00 Nm3/h
                  0001
0 0 0 0 0 0 0 0.  Nm3
FlowV 0.0000     Nm/s
    
```

In this interface, double-click to select the common parameter query.

```

1. Common Functions
2. Common parameters
3. Calibration parameter
0000
    
```

In this interface, press  to enter the common parameter query menu.

↓

```

Vol :           0.0000V
Overflow: 0
    
```

Under the Query menu, press  to save and re-enter the main page display.

Press  to calibrate the zero point. Zero calibration is to calibrate the piping in a closed, non-ventilated condition. The overflow flag is 1 when the flow rate exceeds 100000000. When this bit is greater than 10, it is automatically cleared. When the accumulated flow is cleared, this bit is also cleared.

Press  under this menu to return to the main page.

```

OK SAVE UP LP      V: 0.000V
Instant           0.00 Nm3/h
                  0001
0 0 0 0 0 0 0 0.  Nm3
FlowV 0.0000     Nm/s
    
```

In this interface, press three times to select the calibration parameter settings.

```

1. Common Functions
2. Common parameters
3. Calibration parameter
0000
    
```

In this interface, press  to enter the common parameter query menu.

Appendix 1. Troubleshooting and Repair

Fault	Cause	Solution
No display	1. No power supply	Get power supply
	2. SMPS is damaged	Get power supply, if the power indicator light is out, it means that the SMPS is damaged, Please contact supplier.
	3. The wirings of DC24V are reversed	Check the wirings, make the wirings right
	4. The position of LCD is wrong	Reinstall the LCD
	5. The LCD is damaged	Check the power indicator light. If the light is on, it means that the LCD is damaged. Please contact supplier
Low velocity	1. The wirings of sensor are reversed	Rewiring or reinstall the sensor
	2. The sensor is dirty	Clean sensor
	3. The sensor is damaged	Return to supplier
	4. Some parameters of flow setting are wrong	Check the parameters setting
Abnormal velocity and large fluctuation	1. Some parameters of velocity setting are wrong	Check the parameters setting
	2. Fluid properties is pulsating in turn	Adjust the system filter
	3. The sensor is dirty	Clean sensor
	4. The sensor is damaged	Return to supplier
Abnormal 4-20mA output	1. The setting of 20mA range is wrong	Right settings
	2. The Transmitter has fault	Return to supplier
	3. The connection is not a loop circuit	Check the connection
Abnormal frequency output	1. Some parameters of frequency setting are wrong	Right settings
	2. The Transmitter has fault	Return to supplier
	3. The connection cable is damaged	Check the connection
Abnormal alarm	1. Some parameters of setting are wrong	Right settings
	2. The meter has no alarm function	Contact supplier
	3. The relay is damaged	Return to supplier
Abnormal RS485 output	1. The settings of baud rate and address are wrong	Right settings
	2. The wirings are reversed	rewiring
	3. The connection cable is damaged	Check the connection

Appendix 2.

The density and conversion coefficient of common gas

According to different gas on site, the calibration in lab translates the flow rate of actual gas on site into flow rate of air, and then begins to calibrate the flow rate at present. Therefore, when using the meter on site, the meter displays mass flow or volume flow of actual gas.

When translating the flow rate of gas into flow rate of air, there is a conversion coefficient table of different gas.

Table 1 The Density and Conversion Coefficient of Common Gas

	Gas	Specific heat (Kal/g* °C)	Density (g/l* °C)	Conversion Coefficient
0	Air	0.2400	1.2048	1.0000
1	Argon (Ar)	0.1250	1.6605	1.4066
2	Arsine (As H ³)	0.1168	3.4780	0.6690
3	Boron Tribromide (BBr ³)	0.0647	11.1800	0.3758
4	Boron Trichloride (BCl ³)	0.1217	5.2270	0.4274
5	Boron Trifluoride (BF ³)	0.1779	3.0250	0.5050
6	Borane (B ² H ⁶)	0.5020	1.2350	0.4384
7	Carbon Tetrachloride (CCl ⁴)	0.1297	6.8600	0.3052
8	Carbon Tetrafluoride (CF ⁴)	0.1659	3.9630	0.4255
9	Methane (CH ⁴)	0.5318	0.7150	0.7147
10	Acetylene (CH ²)	0.4049	1.1620	0.5775
11	Ethylene (C ² H ⁴)	0.3658	1.2510	0.5944
12	Ethane (C ² H ⁶)	0.4241	1.3420	0.4781
13	Allylene (C ³ H ⁴)	0.3633	1.7870	0.4185
14	Propylene (C ³ H ⁶)	0.3659	1.8770	0.3956
15	Propane (C ³ H ⁸)	0.3990	1.9670	0.3459
16	Butyne (C ⁴ H ⁶)	0.3515	2.4130	0.3201
17	Butene (C ⁴ H ⁸)	0.3723	2.5030	0.2923
18	Butane (C ⁴ H ¹⁰)	0.4130	2.5930	0.2535
19	Pentane (C ⁵ H ¹²)	0.3916	3.2190	0.2157
20	Carbinol (CH ³ OH)	0.3277	1.4300	0.5805
21	Ethanol (C ² H ⁶ O)	0.3398	2.0550	0.3897
22	Trichloroethane (C ³ H ³ Cl ³)	0.1654	5.9500	0.2763
23	Carbon Monoxide (CO)	0.2488	1.2500	0.9940
24	Carbon Dioxide (CO ²)	0.2017	1.9640	0.7326
25	Cyanide (C ² N ²)	0.2608	2.3220	0.4493
26	Chlorine (Cl ²)	0.1145	3.1630	0.8529

27	Deuterium (D ²)	1.7325	0.1798	0.9921
28	Fluoride (F ²)	0.1970	1.6950	0.9255
29	Germanium Tetrachloride(GeCl ⁴)	0.1072	9.5650	0.2654
30	Germane (GeH ₄)	0.1405	3.4180	0.5656
31	Hydrogen (H ₂)	3.4224	0.0899	1.0040
32	Hydrogen Bromide (HBr)	0.0861	3.6100	0.9940
33	Hydrogen Chloride (HCl)	0.1911	1.6270	0.9940
34	Hydrogen Fluoride (HF)	0.3482	0.893	0.9940
35	Hydrogen Iodide (HI)	0.0545	5.7070	0.9930
36	Hydrogen Sulfide (H ₂ S)	0.2278	1.5200	0.8390
37	Helium (He)	1.2418	0.1786	1.4066
38	Krypton (Kr)	0.0593	3.7390	1.4066
39	nitrogen (N ₂)	0.2486	1.2500	0.9940
40	Neon (Ne)	0.2464	0.9000	1.4066
41	Ammonia (NH ₃)	0.5005	0.7600	0.7147
42	Nitric Oxide (NO)	0.2378	1.3390	0.9702
43	Nitrogen Dioxide (NO ₂)	0.1923	2.0520	0.7366
44	Nitrous Oxide (N ₂ O)	0.2098	1.9640	0.7048
45	Oxygen (O ₂)	0.2196	1.4270	0.9861
46	Phosphorus Trichloride (PCl ₃)	0.1247	6.1270	0.3559
47	Phosphorane (PH ₃)	0.2610	1.5170	0.6869
48	Phosphorus Pentafluoride(PF ₅)	0.1611	5.6200	0.3002
49	Phosphorus Oxychloride (POCl ₃)	0.1324	6.8450	0.3002
50	Silicon Tetrachloride (SiCl ₄)	0.1270	7.5847	0.2823
51	Silicon Fluoride (SiF ₄)	0.1692	4.6430	0.3817
52	Silane (SiH ₄)	0.3189	1.4330	0.5954
53	Dichlorosilane (SiH ₂ Cl ₂)	0.1472	4.5060	0.4095
54	Trichlorosilane (SiHCl ₃)	0.1332	6.0430	0.3380
55	Sulfur Hexafluoride (SF ₆)	0.1588	6.5160	0.2624
56	Sulfur Dioxide (SO ₂)	0.1489	2.8580	0.6829
57	Titanium Tetrachloride(TiCl ₄)	0.1572	8.4650	0.2048
58	Tungsten Hexafluoride (WF ₆)	0.0956	13.2900	0.2137
59	Xenon (Xe)	0.0379	5.8580	1.4066

Appendix 3. Upper range value of common gas

(Unit: Nm³/h. The follow table can be extended)

Nominal Diameter (mm)	Air	Nitrogen (N ₂)	Oxygen (O ₂)	Hydrogen (H ₂)
15	65	65	32	10
25	175	175	89	28
32	290	290	144	45
40	450	450	226	70
50	700	700	352	110
65	1,200	1,200	600	185
80	1,800	1,800	900	280
100	2,800	2,800	1,420	470
125	4,400	4,400	2,210	700
150	6,300	6,300	3,200	940
200	10,000	10,000	5,650	1,880
250	17,000	17,000	8,830	2,820
300	25,000	25,000	12,720	4,060
400	45,000	45,000	22,608	7,200
500	70,000	70,000	35,325	11,280
600	100,000	100,000	50,638	16,300
700	135,000	135,000	69,240	22,100
800	180,000	180,000	90,432	29,000
900	220,000	220,000	114,500	37,807
1,000	280,000	280,000	141,300	48,120
1,200	400,000	400,000	203,480	69,972
1,500	600,000	600,000	318,000	101,520
2,000	700,000	700,000	565,200	180,480

The flow rate in standard condition: The flow rate is in the condition of 20°C temperature and 101.325kPa pressure.

The unit of flow rate is optional: Nm³/h, Nm³/min, L/h, L/min, t/h, t/min, kg/h or kg/min.

The reduction formula of flow rate in working condition and flow rate in standard condition

$$Q_s = \frac{0.101325+p}{0.10325} \times \frac{273.15+20}{273.15+t} \times Q_n$$

Q_s: The flow rate in standard condition (Nm³/h).

Q_n: The flow rate in working condition (m³/h).

t: The medium temperature in working condition (°C)

p: The medium pressure in working condition (Gauge pressure, MPa)