

MU_GT400_Vortex flowmeter

Manual

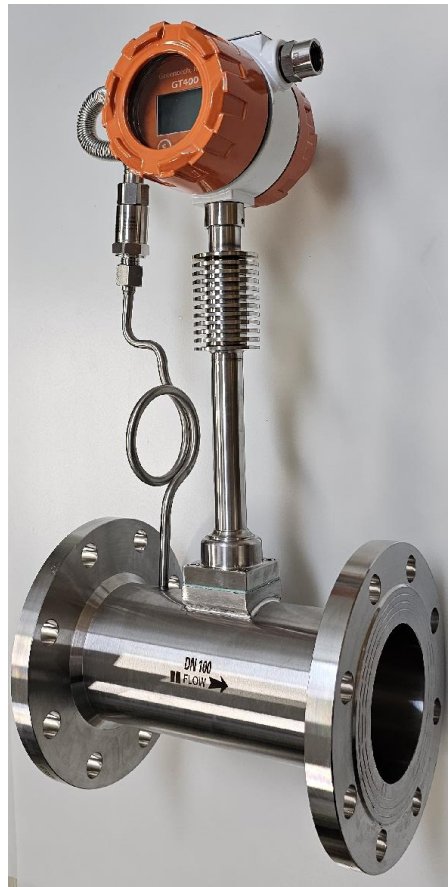

Greentech Korea Co., Ltd.

www.gtc-baruntech.co.kr
www.greentechkor.com

Part 1 Overview

1. Lattice LCD display
2. Easy operation
3. Configure with temperature/pressure sensor. For temperature sensors, Pt100 or Pt1000; For pressure sensor, gauge pressure sensor or absolute pressure sensor
4. Multiple Outputs can be optional: Two-Wire 4-20mA, Three-Wire pulse and Three-Wire equivalent output
5. Excellent nonlinearity correction function, greatly improve the appearance of linearity
6. Spectral analysis, improve the ability of anti-interference and vibration resistance
7. A variety of measuring medium: vapor, liquid, gas and natural gas, etc.
8. Low power consumption, a dry cell can maintain at least 3 years
9. Automatic switching ability of the working modes: Battery supply, Two-Wire and Three-Wire
10. Self-checking function: the rich self-checking information make easy maintenance and debugging
11. Independent password setup, the parameters setup, total flow reset and calibration can be set
12. With different- level passwords, it is convenient for management
13. Three-Wire system supports RS485 communication
14. The display unit can be selected and user-defined

Part 2 Operation Instruction

2.1 Keypad Operation

The meter is operated by keypad, and there are some parameters need to be set when installing.

There are three keys: **S**, **OK** and **M/R** from left to right.

S is Shift Key, **OK** is Enter/Next Key,

and **M/R** is Modify/Return Key.

(If there are some special functions of keys, please follow the instruction below the LCD)

When the system is running, pressing **M/R** key can switch to main screen 2/main screen 3.

If want to quit code setting, please hold **S** then press **OK** at the same time.



2.2 Power on

After powering on, the meter will do self-checking.

If the system is abnormal after self-checking, the meter will display the interface of error self-checking (Details in self-test menu).

1~2 seconds later, the meter will enter the main screen 1 automatically.

If the system is normal, the meter will enter the main screen 1 directly.

The main screen 1 is shown as below:

Main Screen 1:

1. The running status of meter. If the system of meter is working well, it displays "OK". Otherwise it displays "ERR".
2. Steam compensation tips, BH for saturated steam, GR for superheated steam;
3. Pressure sensor type hints. When the sensor is gauge pressure sensor display "GP", when the sensor for absolute pressure sensor display "AP".
4. Temperature and pressure parameter overflow, If the system of meter is abnormal or the temperature is manually set, it displays "ST". If they are temperature sensors and the temperature sensors are working well, it will be blank. (The temperature range is $-50^{\circ}\text{C} \sim +300^{\circ}\text{C}$), If the system of meter is abnormal or the pressure is manually set, it displays "SP". If it is pressure sensor and the pressure sensor is working well, it will be blank. (The absolute pressure range is 50KPa - 20000KPa); When the temperature and pressure are abnormal or manual settings, display "TP".
5. Indicator of operation parameters overflow. If the operation parameters overflow, it displays "OV". If the system of meter is working well, it will be blank. (Overflow includes the parameters which can't be negative are negative, the parameters which can't be zero are zero, and parameters beyond the indication range.)
6. Instrument communication state information display, before three are expressed, and the four said the parity bit, 0: no parity; 1: odd parity; 2: parity check; fifth, said the baud rate, the 0:1200; 1:2400; 2:4800; 3:9600. When the table number is 1, check for no parity, baud rate is 9600, the display interface prompt displays "00103". The instrument output current if the output current overflow overflow flag, display "mA", the normal display parameters for communication.
7. Indicator of running modes. It displays the battery voltage in battery mode, displays "II" in two-wire current mode, and displays "III" in three-wire mode.
8. Flow rate. The maximum value is 9999 999.
9. Total flow. The maximum value is in 8 bits, and if total flow is more than 8 bits, it will display 9999 9999.
10. Temperature. If the internal setting is manually set, it displays the setting temperature. Otherwise it displays the temperatures which are collected by the temperature sensors on-the-spot.
11. Pressure. If the meter is set in manual mode, it displays the setting pressure. Otherwise it displays the pressure which is collected by pressure sensor on-the-spot.

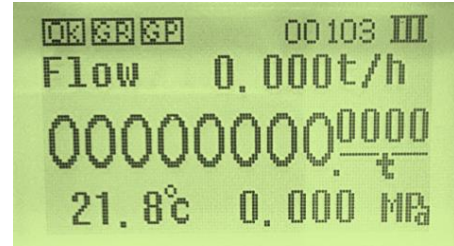

Main Screen 2:

Display flow rate in real-time working condition, total flow in standard condition, current temperature and pressure.

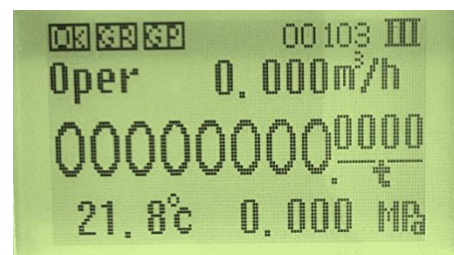

Main Screen 3:

- 123.4Hz: Display the running frequency of sensor, the maximum value is 9999.
- Fz1.0017: Medium density or compressibility factor. If the measured medium is fluid, it displays the set density. If the measured medium is natural gas, it displays compressibility factor. Otherwise it will be blank.
- Oper 0.000m³/h: Flow rate in working condition, the maximum value is 9999999.
- Flow 0.000m³/h: Flow rate in standard condition, the maximum value is 9999999.

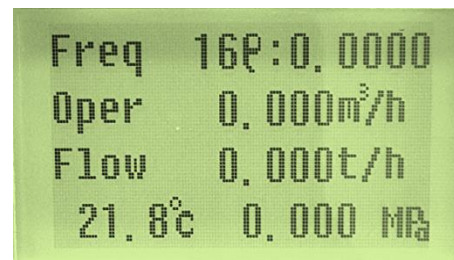

2.3 Main Menu

-- Main menu --	
1.	Record query
2.	Self-test
3.	Total reset
4.	Setup
5.	Calibration
6.	Password
7.	Display unit

In the **main screen 1**, **main screen 2** or **main screen 3**, press **OK** key to enter main menu, press **S** Shift key to select submenu, and then press **OK** to enter.

- 1) **Record query**: Query the operation record of meter.
- 2) **Self-test**: Check the running status of meter.
- 3) **Total reset**: Reset total flow.
- 4) **Setup**: Set the operating parameters of meter.
- 5) **Calibration**: Set the parameters of temperature, pressure, current output and flow coefficient.
- 6) **Password**: Modify the passwords of setup, total reset and calibration.
- 7) **Display unit**: Change the display unit of flow, temperature and pressure.

2.4 Record query

Day	record	
Month	record	
Year	record	
Shift	Enter	Exit

In Record query menu, users able to view all the operation records by daily, monthly and yearly basis. Press **S** key to select the option, and press **OK** to enter.

2.5 Self-test

Self-test	
Clock√	Memory√
Power√	AC con√
Param√	Sensor√

If the system of meter is abnormal, enter this menu to check the details of running status, √ is ok, and **X** means this option is abnormal.

After powering on, the meter will do self-checking.

If there are one or some abnormal options, the meter will display the self-test menu.

When the meter is running, it also can enter this menu to check the running status of meter.

2.6 Total reset

Total flow reset:		
00000000.0000		
Clear	Exit	Clear

In order to prevent unauthorized operation or wrong operation, it needs to input password before total reset.

Input the correct password by **S** Shift key and **M/R** Modify key, and then press **OK** Enter key to enter.

In the total reset menu, it displays the current total flow.

Press **S** and **M/R** key at the same time to reset total flow. Press

S and **M/R** key at the same time to reset total flow. When the LCD displays 00000000.0000, it means that the resetting is

successful, press **OK** key to return main menu.

2.7 Setup

In Setup menu, it can set the operation parameters of meter. In order to prevent unauthorized operation or wrong operation, it needs to input password before entering this menu. After inputting correct password, the LCD will show as below.

● Setup menu 1

Medium:		
Liquid volume		
Shift	Enter	Rev

Select the measuring medium. It can select the following mediums:

1. Saturated steam temperature compensation (Steam T Cmp)
2. Saturated steam pressure compensation (Steam P Cmp)
3. Superheated Gas (Super Heat)
4. Steam automatic compensation (Steam Auto)
5. Gas volume in standard condition (Compress Gas)
6. Gas mass (Gas Mass)
7. Liquid mass (Liquid Mass)
8. Liquid volume (Liquid Volume)

According to different measuring medium, the parameters which are needed to set are different. If select liquid mass and liquid volume, enter **Setup menu 2**. Otherwise enter **Setup menu 7**.

● Setup menu 2

Medium Density:		
1000.000 Kg/m ³		
Shift	Next	Rev

Medium Density.

Set the density of the medium at 20°C. Please pay attention to the unit of density.

● Setup menu 3

Expansion Coe:		
0.000000		
Shift	Next	Rev

Coefficient of cubical expansion.

Use this parameter to correct the density of measuring liquid.

● Setup menu 4

Low flow cut:		
0000.00 m ³ /h		
Shift	Next	Rev

Low flow cut off.

When the flow of interference signal is less than this value, the meter will set the flow zero automatically. This setup can well restrain interference of low frequency.

● Setup menu 5

Flow range.

Set the maximum flow, and this value is the corresponding value of

Flow scale:		
000000.00 m ³ /h		
Shift	Next	Rev

● Setup menu 6

Pulse:	rate	
Scale:	000001.00	
Freq:	0000-50000Hz	
Shift	Next	Rev

● Setup menu 7

Damping time:	0	
Aseis coe:	0	
Shift	Next	Rev

● Setup menu 8

Band:	0/7	
Filter:	0/7	
Gain:	12/15	
Shift	Next	Rev

● Setup menu 9

Device ID:	0001	
Baud rate:	9600	
Parity:	NONE	
Shift	Next	Rev

● Setup menu 10

T input:	Setup	
T setup:	+020.0	
Normal T:	+020.0	
Shift	Next	Rev

20mA when there is 4-20mA output.

Equivalent and Pulse output.

If selecting “pulse”, the output is used for equivalent output (Total flow).

If selecting “rate”, the output is used for pulse output (Flow rate). When selecting “rate”, the first value of Freq is the frequency of pulse which is correspond to flow 0, and the second value of Freq is the frequency of pulse which is correspond to maximum flow, The Scale can't be zero or negative.

Damping time, 0-9.

“Aseis coe” is vibration resistance coefficient. 0 means no vibration resistance.

This value is larger, the more strange ability of vibration resistance could have.

But the large coefficient also might resist irregular flow signal. Adjust this value flexibly according to different applications.

Frequency band adjustment (Band), Filtering adjustment (Filter) and Gain adjustment (Gain).

Using the three parameters accurately can make the meter working in the best performance (Laypeople shouldn't be permitted to modify this menu).

Set Device ID, Baud rate, Parity of RS485 communication.

T input: Collection mode of temperature signal and temperature setup.

The temperature range is -999.9- 999.9, and the unit is °C.

If the collection mode is “setup”, the meter will correct the flow by setting temperature.

T setup: Temperature setup. There are two collection modes of temperature signal (Temperature sensors and setup).

When the temperature of sensor is too large or invalid, the meter calculates the flow with the setting temperature. The default value is 20°C.

Normal T: The temperature in standard condition, operation data when measuring gas.

● Setup menu 11

P input:	Setup
P setup:	+00800.0
Atmo P:	101.325
Shift	Next Rev

P input:

Input collection mode of pressure. It can select "setup" or "sensor". If selecting "setup", the meter will compensate the flow with the setting pressure.

P setup: Pressure setup, absolute pressure of operation parameters. Unit is KPa.

Atmo P: Atmosphere pressure. Set as the average atmosphere pressure in local. Use this value to calculate flow. Unit is KPa.

● Setup menu 12

High alarm:	
Param:	None
level:	low
Shift	Next Rev

High alarm.

Set the parameter of high alarm and electrical level of alarm output. (HART board doesn't support this function)

● Setup menu 13

High alarm value:	
	+000000.0000
Hyst:	000.000
Shift	Next Rev

High alarm value.

Set the high alarm value and difference value. Difference value is used to prevent alarm vibration around high alarm value. The difference value can make the alarm vibration in control area but reduce the control precision at the same time. Set this value according application and experience.

● Setup menu 14

Low alarm:	
Param:	None
level:	low
Shift	Next Rev

Low alarm.

Set the parameter of low alarm and electrical level of alarm output.

● Setup menu 15

Low alarm value:	
	+000000.0000
Hyst:	000.000
Shift	Next Rev

Low alarm value.

Set the low alarm value and difference value. Refer to high alarm value.

● Setup menu 16

Equivalent coe:	
	000.0100
Shift	Next Rev

Equivalent coefficient.

Equivalent equals to specific or common numerical quantity. This value used to make the flow rate to output equivalent pulse. Unit is m³/p (m³/p is cubic meter per pulse).

● Setup menu 17

Clock setup.

Display and set current data and time.

Clock setup:		
2023-03-28		
08:23:38		
Shift	Exit	Rev

2.8 Calibration

Temp channel
Pressure channel
Current output
Flow coefficient

T zero:	+0.00	
T coe:	1.000	
Sensor:	Pt100	
Shift	Exit	Rev

P zero:	+0.00	
P coe:	1.000	
P gain:	5/7 AP	
Shift	Next	Rev

The parameters in this menu are very important.

In order to prevent unauthorized operation or wrong operation, it needs to input password before entering this menu.

In this menu, there are four options: Temperature channel, Pressure channel, Current output and Flow coefficient.

Press  Shift key to select options.

Temperature channel: Input correction coefficient and sensor type to correct the temperature which is collected by temperature sensor.

If the collection mode of temperature signal is temperature setup, there is no need to set these parameters.

T Zero: When calculating flow, use the temperature collected by temperature sensor adding T zero.

T coe: Correct the temperature in a multiple. If not, T coe is 1.

Sensor type can select Pt100 or Pt1000.

Pressure channel: Input correction coefficient to correct the pressure which is collected by pressure sensor. If the collection mode of pressure signal is pressure setup, there is no need to set these parameters.

P Zero: The calculating pressure is the pressure collected by pressure sensor adding P zero.

P coe: Correct the pressure in a multiple. If not, P coe is 1.

P gain: Amplification factor of signal collected by pressure sensor.

GP: Gauge pressure sensor;

AP: Absolute pressure sensor.

Press  Next key to enter the second correction of pressure channel.

Second correction of pressure channel: It can correct pressure second time, and there are five sections. It is suitable for application requiring higher pressure accuracy. Std is standard pressure value, and Test is the pressure value measured by sensor.

P	coe:	sect	0
Std:	00000.0 Kpa		
Test:	00000.0 Kpa		
Shift	Exit	Rev	

Current mode:			
Current zero:			
20 / 40			
DC	Exit	Inc	

Flow	coe:	Sect	0
Freq:	5000		
Coe:	000000.0000		
Shift	Next	Rev	

Average	flow	coe
000000.0000		
Shift	Exit	Rev

Current output: input correction parameter to adjust the zero point of current output.

Note: if modifying this parameter, it will shut off the current output. Therefore, if the current output is in use, please don't modify this parameter

Flow coefficient:

When setting flow coefficient, it can set by section, the number of sections is 0~9.

Freq: Frequency of section, the input range is 0-9999.

Coe: Flow coefficient corresponding to different section.

After calibration, input the frequency of section and flow coefficient from section 0 to section 9.

Note: If the ten sections are not all in use, for example, there are five sections in use (Section 0 to section 4), set section of frequency 5000 and flow coefficient of section 4 in section 5.

Press  Next key to enter the average flow coefficient.

Average flow coefficient: It is used for non-linearity correction.

When the coefficients of section close up to the average flow coefficient, then it can reduce the nonlinear error greatly, and improve the accuracy of meter.

2.9 Password

Setup	pwd	
Total	reset	pwd
Calibration	pwd	
Shift	Enter	Exit

Setup	pwd	
Old	pwd:	0*****
New	pwd:	*****
Shift	Enter	Rev

In this menu, it can modify the password of total reset, setup and calibration.

Enter this menu, press  Shift key select the option which is needed to modify, enter, input the old password, and then input

new password in new password option, press  Enter key.

If the old password is correct, the LCD will display modification successful, and then enter main screen 1 automatically.

Otherwise the LCD will display modification failed, and then enter main screen 1 automatically.

2.10 Display unit

Flow unit:	t/h
O.F unit:	m ³ /h
T unit:	°C
P unit:	KPa

Total unit:	<input type="text" value="t"/>	
Shift	Exit	Rev

Flow: The unit of standard condition. If the medium is liquid mass, the unit can be selected t/h, t/min, kg/h and kg/min. If the medium is liquid volume, the unit can be selected m³/h, m³/min, l/h and l/min.

O.F: The unit of working condition.
The unit can be selected m³/h, m³/min, l/h and l/min.

T: The unit of temperature.

P: The unit of pressure.

Select the needed unit, and then press  Enter key, the main screen will display with the selected unit.

Part 3 Electrical Outputs Connection

3.1 Sensor Connection

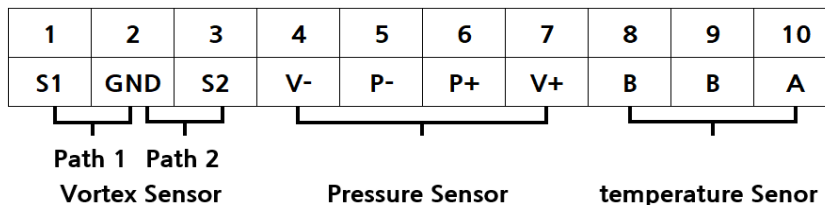

- **Path 1 of vortex sensor:**

S1: +
GND: -

- **Path 2 of vortex sensor:**

S2: +
GND: -

- **Pressure Sensor:**

V-: Pressure sensor power supply –
P-: Pressure sensor signal –
P+: Pressure sensor signal +
V+: Pressure sensor power supply +

● Temperature Sensor:

- B: Pt100 (1)
- B: Pt100 (1)
- A: Pt100 (2)

3.2 Outputs Connection

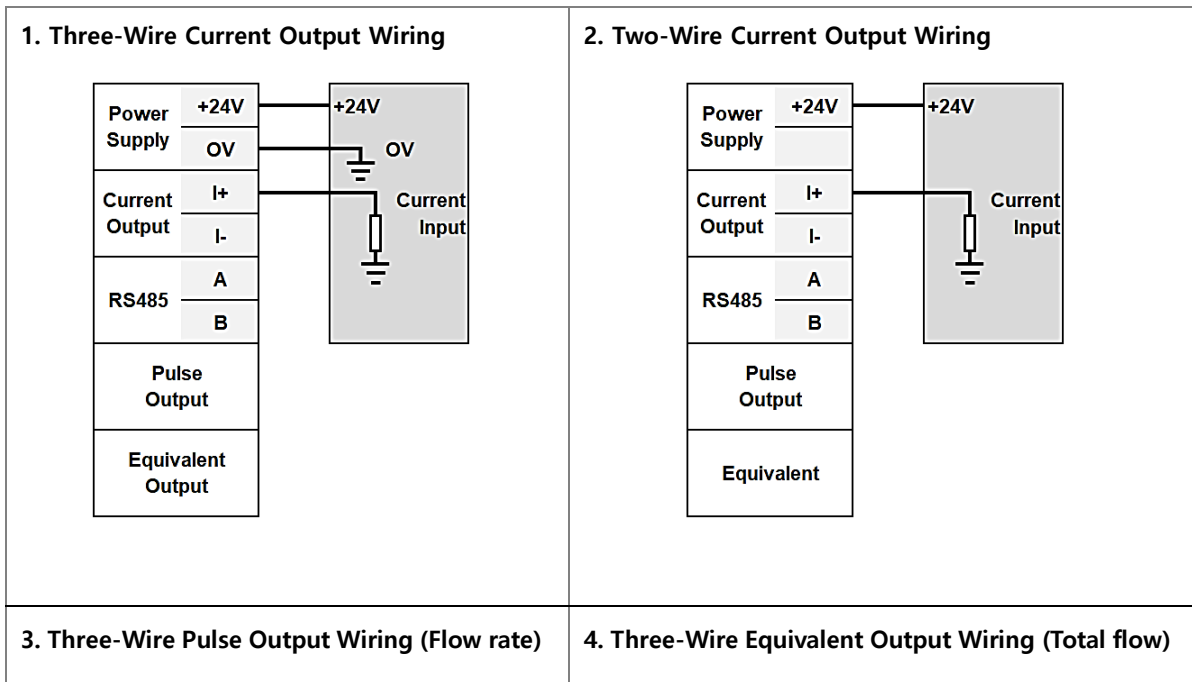

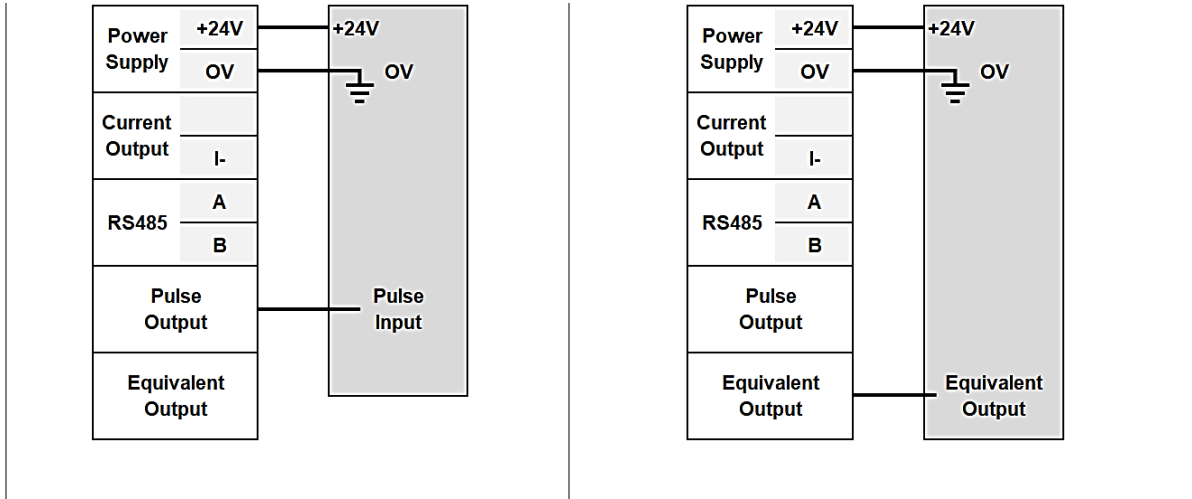

5. The wirings of RS485 output

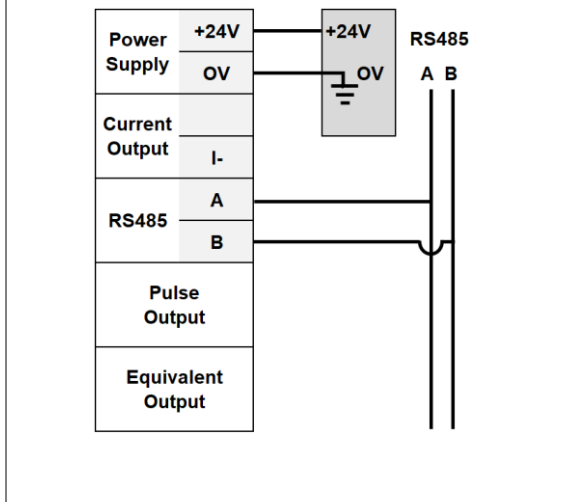

Part 4 Troubleshooting

Fault	Cause	Solution
<p>No output signal after power on</p>	<ol style="list-style-type: none"> 1. No fluid flowing or the flow rate is under starting flow. 2. The connections of power supply and output are incorrect. 3. The pre-amplifier is damaged (The calculator can't count, and the flow rate is 0). 4. The circuit of driving amplifier is damaged (The display of calculator is normal). 	<ol style="list-style-type: none"> 1. Increase the flow rate or replace a flow meter with smaller nominal diameter to meet the requirement of flow range. 2. Make the connection correct. 3. Replace the pre-amplifier. 4. Replace the damaged components in the circuit of driving amplifier.

The meter outputs signal when no flow	<ol style="list-style-type: none"> 1. The interference of bad grounding of meter, strong electricity and interference of other grounding. 2. The higher sensitivity of amplifier or it may produce self-excitation. 3. Unstable power supply, bad filtering or other electrical disturbance. 	<ol style="list-style-type: none"> 1. Make the grounding well 2. Replace the pre-amplifier. 3. Repair or replace the power supply.
Unstable display of flow rate	<ol style="list-style-type: none"> 1. Unstable flow in pipe 2. The higher or lower sensitivity of amplifier make the output pulses are more counted or less counted. 3. There is debris in the shell of meter. 4. Bad grounding. 5. The flow rate is under the low limit. 6. The downstream seal ring reaches into pipe, and make disturbance. 	<ol style="list-style-type: none"> 1. Begin to measure after the flow rate is stable. 2. Replace the pre-amplifier. 3. Remove the debris. 4. Check the grounding, make the grounding well.
The displayed total flow is inconsistent as actual total flow	<ol style="list-style-type: none"> 1. The flow coefficient of meter is incorrect. 2. The flow rate on site is higher than the maximum flow of meter. 3. The bad quality of the flow meter. 	<ol style="list-style-type: none"> 1. Recalibrate the meter and input the new flow coefficient. 2. Reduce the flow rate in pipe or Replace the flow meter. 3. Recalibration
Abnormal display	<p>Bad contact of the key or dead lock the key</p>	<p>Replace the display board.</p>
System halts after replacement new battery	<p>The electrify reset circuit is abnormal, or the oscillating circuit can't afford to boost.</p>	<p>Reinstall the battery (Before reinstall the battery, the meter is needed to discharge more than 5 seconds)</p>