

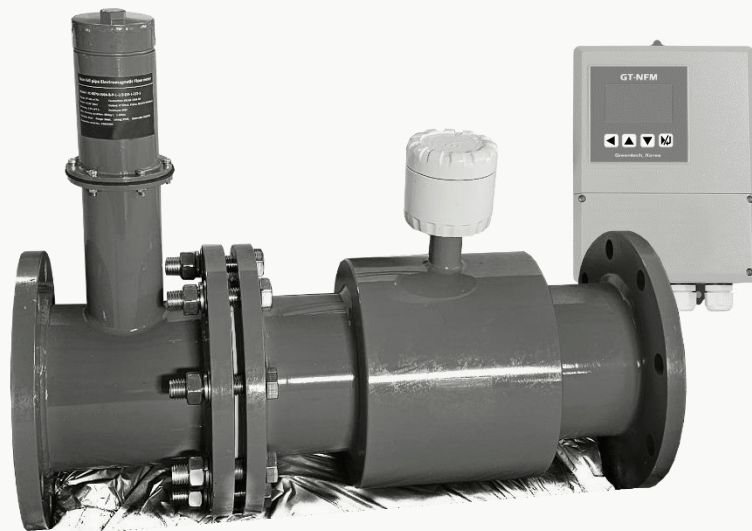

Operation & maintenance Manual

Non-full pipe

Electromagnetic flowmeter: GT-NFM





Index

1. Product function description	2
1.1 basic functions	2
1.2 working conditions	2
1.3 connection type with sensor	3
1.4 display content	4
1.5 key function	4
2. Technical performance index	5
2.1 executive standards	5
2.2 basic parameters and performance indexes	5
3. Dimensions of meter and converter	6
3.1 Meter (Rubber/ PTFE lining)	6
3.2 Converter	6
4. Menu operation	7
4.1 enter menu	7
4.2 main structure of menu	7
4.3 flow parameter setting	7
4.4 alarm parameter setting	10
4.5 output parameter setting	11
4.6 sensor parameters	13
4.7 communication parameter setting	14
4.8 factory parameters of instrument	14
4.9 level parameter	15
4.10 characteristics and connection requirements of wires and cables	16
4.11 digital output and calculation	16
5. Parameter setting of non full tube flowmeter	17
6. Installation requirements and use of flowmeter	17
7. Alarm information	18
8. Troubleshooting	18
Appendix 1 description of nonlinear correction function	19
Technical information	20

1. Product function description

The **Non-full pipe Electromagnetic flowmeter** is a kind of automatic flow measurement which uses the velocity area method to continuously measure the fluid flow in not filled pipelines (such as half pipe sewage pipeline and large flow pipeline without overflow weir). It can measure and display the data of instantaneous flow, velocity and cumulative flow.

It is especially suitable for the discharge of municipal rainwater, wastewater and sewage, and irrigation water pipeline.

The Electromagnetic flowmeter of not filled Tube fully, which is composed of a velocity sensor, a water level sensor and a flow indicator. It can continuously measure the flow rate and liquid level of the fluid in the pipeline.

As long as the user inputs the inner diameter of the circular pipe or the width of the square pipe, the non-full pipe flowmeter will automatically calculate the flow in the pipe, and automatically display the instantaneous flow and flow in the pipeline Speed, cumulative flow and other measurement parameters.



1.1 Basic function

- The internal working current option is set as 50mA and 100mA;
- Flow rate measurement range: 0.03-10.00 M/s, velocity resolution: 1 mm/S;
- Digital signal output: MODBUS(RTU), TTL level;
- Display in English;
- It can be used to measure the flow rate of open non full pipe (round pipe and rectangular pipe);
- It can be used for continuous measurement of municipal rainwater, wastewater, sewage discharge and irrigation water pipeline
- Bidirectional and reverse flow measurement
- The sensor can work for a long time under harsh site and sewage quality
- The flow measurement accuracy is high, and it is not affected by the downstream, tributary water, blocking and other factors
- The straight section of the measuring pipe is required to be 10 times the pipe diameter
- The backlight LCD can read the measurement data clearly in strong light or at night
- The non full tube flowmeter has complete display and output functions, which can display instantaneous flow rate, flow rate, cumulative flow rate and other data, and has computer communication interface 232, 485 (optional)
- with GSM and GPRS wireless data remote transmission function (optional)
- Nominal diameter: round pipe DN150~DN2000
- Rectangular pipe width \leq 6m, depth \leq 6M

1.2 Normal working conditions

- Ambient temperature: -10~+ 60°C (the liquid in the pipeline will not freeze);
- Relative humidity: 5%~90%;
- Power supply: 220VAC or 24VDC 200Ma;
- Dissipation power: less than 15W(after connecting the sensor)



1.3 Connection type with sensor

Split type: square housing, simultaneous interpreting of the shell through communication cable and sensor.

1.3.1 Connection between sensor and transmitter of non full tube flowmeter

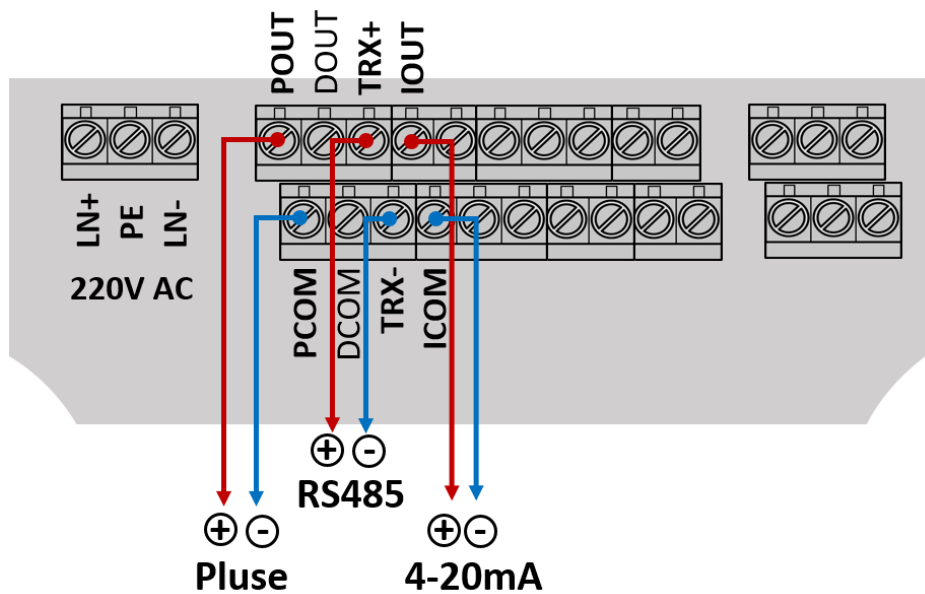
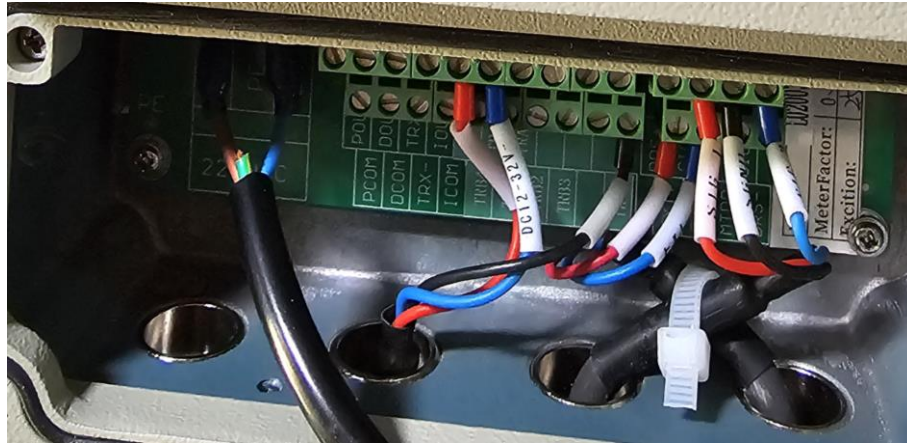

1.3.2 External wiring of non full tube flowmeter sensor

There are blue, red and yellow wires outside the sensor of the non full tube flowmeter. The IP66 waterproof connector is used to connect with the transmitter. The color of both ends of the waterproof joint must be the same when connecting.

There are 2 pins in the blue connector, 3 pins in the red connector and 3 pins in the Yellow connector. After the butt joint is inserted, it shall be inserted again with force, and then the nut of waterproof joint shall be tightened.

1.4 Display contents

When powered on, it will automatically enter the measurement state. In the automatic measurement state, the non full tube flowmeter automatically completes each measurement function and displays the corresponding measurement data.

The default display interface is as follows:

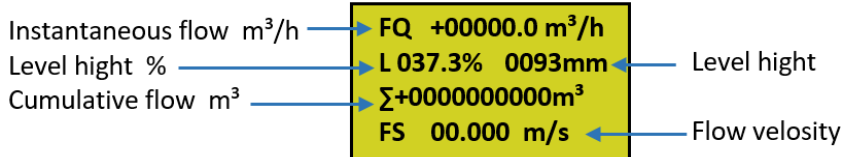



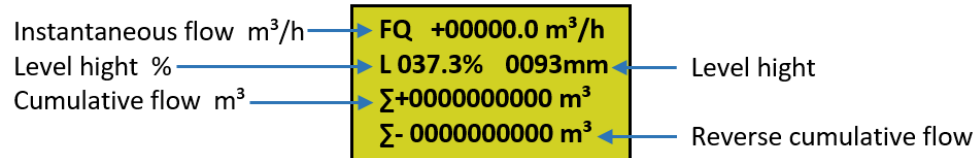
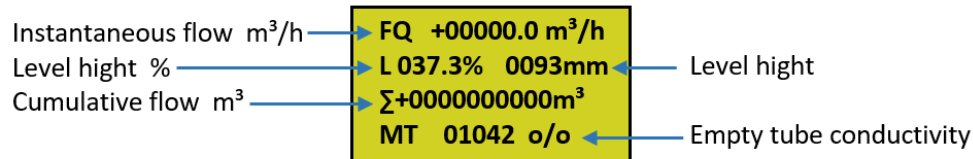
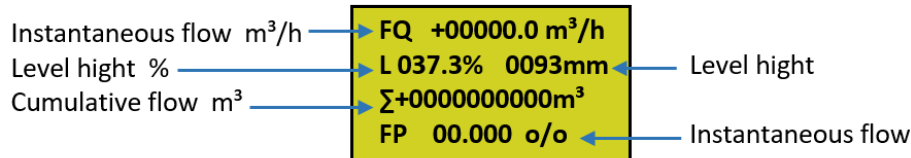

Press ▼ will display other interfaces. The contents of lines 1-3 same as the display interfaces above, but the contents of the bottom line are different.



1.5 Key function

The buttons from left to right are:

-  **Left shift key:** move the cursor clockwise.
-  **Up shift key:** Enter key, move up key, number plus 1, turn back key.
-  **Down shift key:** exit key, down move key, number minus 1, forward page key.
-  **Right shift key:** move the cursor anticlockwise.

In order to set or modify the parameters of the non full tube flowmeter, it is necessary to make the flow meter from the measurement state to the parameter setting state.

In the parameter setting state, the user uses the panel key to complete the parameter setting of the non full tube flowmeter.



1.5.1. Key function in automatic measurement state

Up key: cycle to select the display content of the screen;

Right shift key: press the right shift key once to enter the function selection screen of the non full tube Flowmeter

1.5.2. Key function in automatic measurement state

Down key: the number at the cursor minus 1, page forward;

Up key: add 1 to the number at the cursor, then turn the page;

Submenu: When the cursor moves below the down key, press the key to return to the previous menu.

2. Technical performance index

2.1 Executive Standards

The design, production and testing of the non full tube flowmeter shall comply with the enterprise standard.

2.2 Basic parameters and performance indicators

- **Measurement of basic pipe size (mm)**
DN150~DN2000
- **Measurement accuracy of the whole machine**
Measurement accuracy: 2.0- 2.5%
- **Protection level**
IP68 pipe type current meter for velocity measurement
Ultrasonic level gauge IP65 for water level measurement
Pressure water level gauge IP68 for water level measurement
Flow indicator IP55.
- **Analog current output**
Load resistance: 0~550Ω at 4~20mA.
Basic error: 0.1~0.2%

3. Dimensions of meter and converter

3.1 Meter (Rubber/ PTFE lining) & Converter

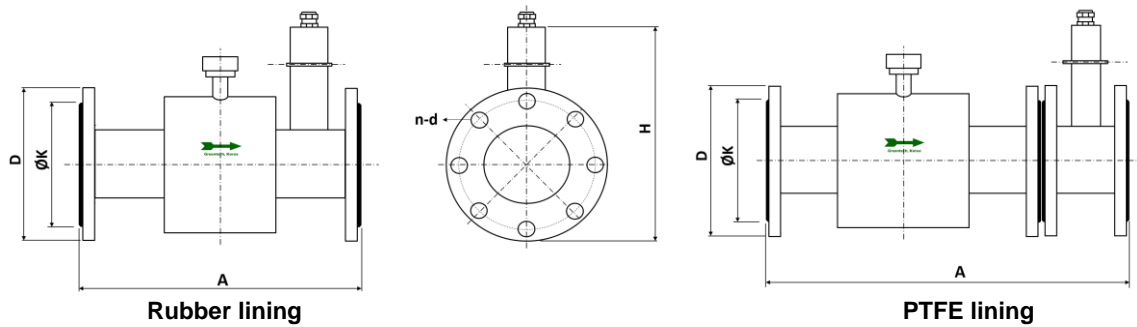

Meter size		A Lining		ØD	ØK	H	N*d
mm	Inch	Rubber	PTFE				
150	6"	460	660	285	240	485	8*M20
200	8"	510	710	340	295	540	8*M20
250	10"	610	810	395	350	595	12*M20
300	12"	650	850	445	400	645	12*M20
350	14"	700	900	505	460	705	16*M20
400	16"	750	950	565	515	765	16*M24
450	18"	750	950	615	565	815	20*M24
500	20"	750	950	670	620	870	20*M24
600	24"	750	950	780	725	980	20*M27
700	28"	850	1050	895	840	1095	24*M27
800	30"	952	1152	1015	950	1215	24*M30
900	36"	1050	1250	1075	1020	1300	24*M30
1000	40"	1150	1350	1175	1120	1400	28*M30
1200	48"	1350	1550	1405	1340	1605	32*M30

3.2 Converter

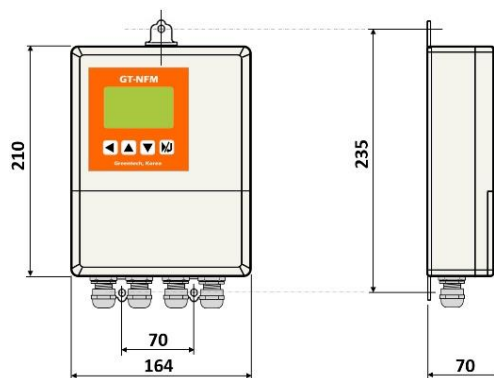

4. Menu operation

4.1 Enter menu

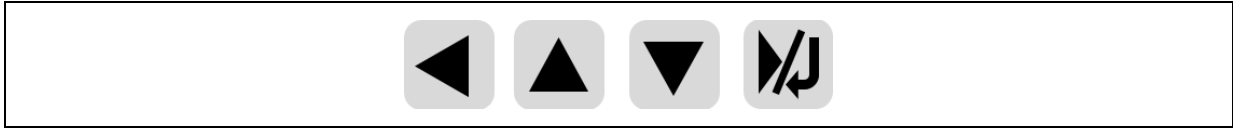

When the measured flow status is displayed normally, press the right shift key to enter the menu, and the password input prompt appears :



Input the password 19818, then move the cursor to the down shift key, and press the down shift key to enter the menu.

4.2 Main structure of menu

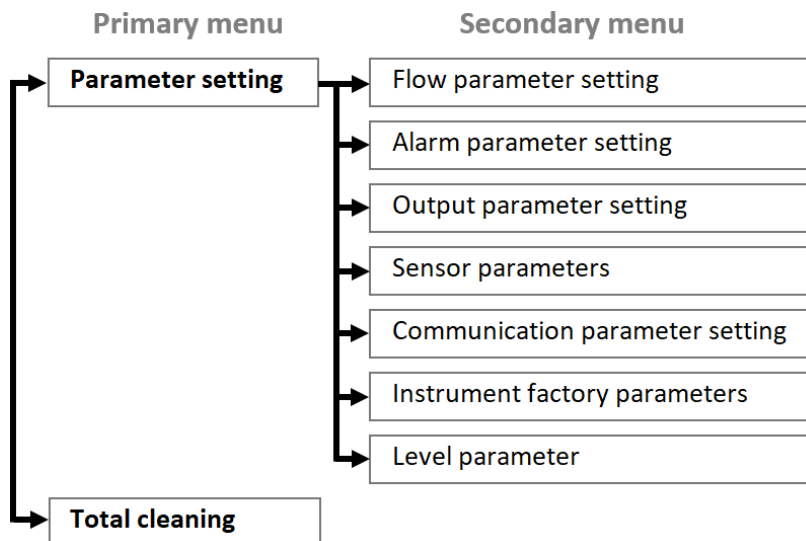

4.3 Flow parameter setting

4.3.1 Unit of flow (unit of instantaneous flow)

The instantaneous flow display units of non full tube flowmeter include: m^3/h , m^3/m , m^3/s , L/h, L/m, L/s. The default value is " m^3/h ". The user can select a required flow display unit.

" m^3/h " means: cubic meter /hour;

" m^3/m " means: cubic meter/minute;

" m^3/s " means: Cubic meters/second;

"L/h" means: liter/hour;

"L/m" means: liter/minute;

"L/s" means: liter/second;

4.3.2 Flow accumulation unit

The transmitter display is a 9-digit counter, and the maximum allowable count value is 99999999.

The unit of accumulated calculation is L, m³ (liter, cubic meter). This unit is automatically set to be the same as the flow unit. When the flow unit is L/h, L/m, L/s, the accumulation unit is L; when the flow unit is m³/h, m³/m, m³/s, the accumulation unit is m³.

There are several flow accumulation units as following:

"1. m³" means: 1.0 cubic meter;

"0.1 m³" means: 0.1 cubic meter;

"0.01m³" means: 0.01 cubic meter;

"0.001m³" means: 0.001 cubic meter;

"1. Ltr" means: 1.0 liter;

"0.1 Ltr" means: 0.1 liter;

"0.01Ltr" means: 0.01 liter;

"0.001Ltr" means: 0.001 liter;

4.3.3 Reverse output allowed

Default: forbidden; optional select "allow."

When the allowable parameter of reverse output is set to "allowed", the transmitter outputs pulse and current according to the flow value as long as the fluid flows, whether it is forward flow or reverse flow. When the allowable parameter of reverse output is set to "forbidden", if the flow rate of the transmitter is normal, the output pulse is "0", the current output is signal "0" (4mA), and the instantaneous flow is displayed as "0".

4.3.4 Instrument range setting

The instrument range setting refers to the upper limit flow value determined, and the lower limit flow value of the non full tube flowmeter is automatically set to "0".

Therefore, the range setting determines the range range of the non full tube flowmeter, and also determines the corresponding relationship between the percentage display, frequency output, current output and flow rate as following:

Percentage display value = (flow measurement value / range) * 100 % ;

Frequency output value = (flow measurement value / range) * frequency full range value;

Current output value = (flow measurement value / range) * current full range value+ base point;

The pulse output value of the non full tube flowmeter is not affected by the range setting of the non full tube flowmeter;

For example, the setting value is 2827.5, indicating that the maximum range of the non full tube flowmeter is "2827.5m³/h". Can be adjusted according to their own requirements, under normal circumstances, this value is not greater than the maximum flow rate per hour of the non full tube flowmeter.

4.3.5 Measure damping time

There are several choices, where SEC stands for the unit of time "seconds."

01 SEC, 02 SEC, 04 SEC, 06 SEC, 08 SEC, 10 SEC, 16 SEC, 30 SEC, 40 SEC.

The results show that the filter time and the long damping time can improve the flow display stability and output signal stability of the non full tube flowmeter, which is suitable for the measurement of the total amount of pulsating flow. The short measurement damping time shows a relatively fast measurement response speed, which is suitable for the production process control.

4.3.6 Analog output damping

There are several choices, where SEC stands for the unit of time "seconds."

000 SEC, 005 SEC, 010 SEC, 020 SEC, 050 SEC, 080 SEC, 150 SEC, 250 SEC.

4.3.7 Spike suppression selection

Default: forbidden; Can select allow.

4.3.8 Peak suppression range

The unit is "second", the minimum is "00.500 m/s", and the maximum is "19.999 m/s".



4.3.9 Spike suppression time

The unit is "second". There are several choices:
2S, 3S, 4S, 5S, 6S, 8S, 10S, 15S, 20S, 30S

4.3.10 Abnormal inhibition time

The unit is "second". There are several choices:
0S, 10S, 15S, 20S, 30S, 40S, 50S, 60S, 70S, 99S

4.3.11 Flow direction selection

Default: forward; reverse is optional.

If the user thinks that the fluid direction during debugging is inconsistent with the design, the parameter can be changed by setting the flow direction.

4.3.12 Signal removal allowed

Default: forbidden; you can select allow.

4.3.13 Small signal cut-off point

The menu displays "0000.0", which can be set by yourself., The unit is "cubic meter / hour".

The setting of small signal cut-off point is expressed by flow rate. When the small signal is cut off, only the flow rate, cut off flow rate, percentage display and signal output are displayed.

4.3.14 Fluid density

The menu displays "1.000", which can be set by yourself, the maximum value is "1.999".

For example, if the density of water is 1000 kg/m³, then "1.000" will be input; if the mud density is 1200 kg/m³, then "1.200" will be input.

4.3.15 Flow zero correction

The zero correction should ensure that the sensor tube is filled with fluid and the fluid is at rest.

The flow zero is expressed in terms of flow rate, in mm/s. The transmitter flow zero correction is shown as follows:

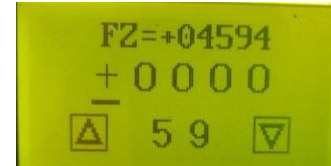

The small characters in the upstream display: FS represents the zero point measurement value of the non full tube flowmeter; the down large font display: the flow rate zero correction value;

When FS display is not "0", the correction value should be adjusted to make FS = 0. Note: if the downward correction value is changed and the FS value increases, it is necessary to change the positive and negative signs of the downlink value so that FS can be corrected to zero.

The correction value of flow zero point is the constant value of the sensor, which should be recorded in the record sheet and label of the sensor. When recording, the zero value of the sensor is the flow rate value in mm/s, and its symbol is opposite to that of the correction value.

4.3.16 Factory calibration coefficient (this item is not allowed to be modified, otherwise the measurement will be wrong)

The coefficient is a special coefficient for circuit board. The coefficient is used to unify the measuring circuit system to ensure the interchangeability of all circuit boards up to 0.2~0.5%.

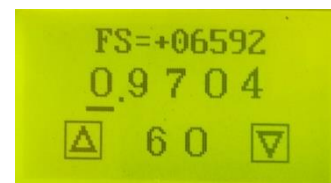

4.3.17 Total clearing password (once the password is entered, the original accumulated traffic will be cleared.)

The user can set the password by using the password above the third level, and then set the password in the total clearing.



4.4 Alarm parameter setting

4.4.1 Alarm output selection

There are: flow upper limit alarm, forbidden alarm output, liquid level lower limit alarm, liquid level upper limit alarm, excitation system alarm, flow cut alarm, flow reverse alarm, flow empty pipe alarm, flow lower limit alarm.

4.4.2 Upper limit alarm allowed

Default: forbidden; Can select "allow".

4.4.3 Upper limit alarm value

If it is set to "2827.4", it means that the instantaneous flow has reached the upper limit of 2827.4 m³/s. when the instantaneous flow of the non full pipe flowmeter is higher than this value, the DOUT terminal of the non full pipe flowmeter will output an alarm signal.

4.4.4 Lower limit alarm allowed

Default: forbidden; Can select "allow"

4.4.5 Lower alarm value

If it is set to "0282.7", it means that the instantaneous flow is lower than the lower limit of 282.7 m³ / s, and an alarm will be given.

4.4.6 Excitation alarm allowed

Default: forbidden; Can select "allow"

4.4.7 Empty tube alarm allowed

Default: forbidden; Can select "allow"

It has the function of empty tube detection without additional electrode. If the user chooses to allow the empty pipe alarm, when the fluid in the pipeline is lower than the measuring electrode, the non full tube flowmeter can detect an empty pipe state. After detecting the empty tube state, the analog output and digital output signals of the non full tube flowmeter are zero, and the flow of the non full tube flowmeter is displayed as zero, and the terminal DOUT outputs low level.

4.4.8 Empty tube alarm threshold

If "00200" is set, the alarm will be given if the measured value is lower than "00200".

When the fluid is full (with or without flow rate), the actual measured conductivity is displayed on the empty pipe alarm threshold parameter, and then the empty pipe alarm threshold value is set. When setting the empty pipe alarm threshold value, it can be set according to the measured conductivity, which can be set to 3-5 times of the measured conductivity. For example, if the measured conductivity is "50", the setting value should be > 150 and < 250.

4.4.9 Empty tube zero correction

When the full pipe value is large, the user can correct the zero point of air traffic control. The sensor tube should be filled with fluid during the zero point correction of the empty pipe. The zero correction of the empty pipe is shown as follows:

The first line shows: MZ represents the zero point measurement value of the empty pipe of the non full tube flowmeter;

The second line shows: Empty tube zero correction value;

Firstly, according to the measured value of conductivity MT, adjust the correction value to make MZ = 5-10 (Note: if the correction value in the second line is increased, the MZ value will decrease).





4.4.10 Empty tube range correction

When the MT value of the empty pipe conductivity measured by the non full tube flowmeter is small, the user can correct the empty pipe range. When correcting the range of the empty pipe, it should be ensured that there is no fluid in the sensor tube. The range correction of the empty pipe is shown as follows:



The first line shows: MR represents the measurement value of empty pipe range of non full tube flowmeter; The second line shows: Empty tube range correction value; When the correction value of the second line is increased, the value of MR increases, and the value of MR decreases when the correction value of the second line is decreased. The user can adjust MR to an appropriate value according to the actual needs (it is suggested to adjust MR to about 500), then the measured conductivity value of empty pipe is basically the actual corrected MR value.

4.4.11 Damping time of empty pipe

There are several choices, where SEC stands for the unit of time
010 SEC, 015 SEC, 020 SEC, 025 SEC, 030 SEC, 035 SEC, 040 SEC, 045 SEC, 050 SEC, 060 SEC, 045 SEC

4.5 Output parameter setting

4.5.1 Pulse output mode

There are two kinds of pulse output modes: frequency output and pulse output

- ① Frequency output mode: the frequency output is continuous square wave, and the frequency value corresponds to the flow percentage. Frequency output value = (measured value of flow value / measuring range of non full tube flowmeter)*full range value of frequency;

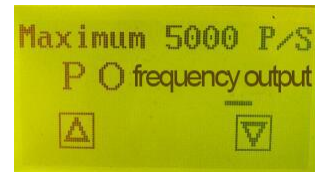

- ② Pulse output mode: the pulse output is rectangular wave pulse train, each pulse indicates that the pipeline flows through a flow unit, and the pulse unit is set by the following two parameters of "pulse unit" and "pulse unit". The pulse output mode is usually used to accumulate the total amount, which is usually connected with the non full tube flowmeter. Frequency and pulse output are usually in OC gate form, so DC power supply and load should be connected externally.

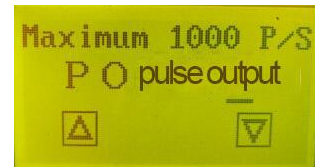

4.5.2 Pulse unit

There are only two kinds, m³ and LTR

4.5.3 Pulse units

The set before leaving factory is "01.000m³", can be modified according to your own needs. The pulse unit refers to the flow value represented by a pulse. The pulse unit of the non full tube flowmeter should be set by the parameters of "pulse unit" and "pulse unit", with the range of 00.001 L ~ 59.999 m³. Under the same flow rate, if the pulse unit is small, the frequency of the output pulse is high and the cumulative flow error is small.

4.5.4 Pulse width (this function is still in the process of testing and may cause errors when using it)

Pulse output is effective at low level, pulse width: 01-500ms, unit: MS.

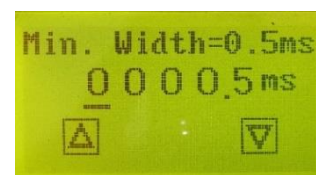

Pulse width---maximum output pulse number corresponding table

Serial number	Pulse width (ms)	Maximum number of output pulses per hour (p/h)
1	1	1800000
2	5	360000
3	10	180000
4	50	36000
5	100	18000
6	200	9000
7	500	3600

4.5.5 Lower limit of frequency output

The factory default is "00000" , which can be set according to your own needs.

4.5.6 Frequency output range

The factory default is "05000", which can be set according to your own needs.

The frequency output range of the non full tube flowmeter corresponds to the upper limit of flow measurement, That is 100% of the percentage flow. The upper limit of frequency output can be set arbitrarily in the range of 1 ~ 10000 Hz.

4.5.7 Current output mode

The factory default is "4-20mA" , which can be set at 4mA , means output all the time.

4.5.8 Current zero correction

For example, the factory setting is "0.1463", which means that the correction value is "0.1463" at 4mA.

The factory default is "00000".

If the measured current is 4.60mA larger than 4mA when corresponding to 4.00mA output, the multimeter can be connected in series to the positive pole of current output, and "0.1463" can be gradually reduced until the output current becomes 4.00mA.

If the measured current is 3.79mA smaller than 4mA when corresponding to 4.00mA output, the multimeter can be connected in series to the positive pole of current output, and "0.1463" can be gradually increased until the output current becomes 4.00mA.

Note: Generally, the current measured by the universal meter with "DC 200mA" will have an error of 0.02-0.04mA. In order to make the measurement result accurate, the multimeter made in Shenzhen Shengli should be selected at least. Do not use a pointer multimeter to calibrate the current.

4.5.9 Current full scale correction

For example, the factory setting is "0.6872", which means that the correction value is "0.6872" at 20mA.

If the measured current is greater than 20mA when the corresponding output is 20.00mA, for example, 20.60mA, the multimeter can be connected in series to the positive pole of the current output, and "0.6872" can be gradually reduced until the output current becomes 20.00mA.

If the measured current is smaller than 20mA at the corresponding output of 20.00mA, for example, 19.49mA, the multimeter can be connected in series to the positive pole of the current output, and "0.6872" can be gradually increased until the output current becomes 20.00mA.

Reminder: Generally, the current measured by the universal meter with "DC 200mA" will have an error of 0.02-0.04mA. In order to make the measurement result accurate, the multimeter made in Shenzhen Shengli should be selected at least. Do not use a pointer multimeter to calibrate the current.

4.5.10 Current output test

It is used to test whether the current output circuit is normal. After entering this menu, the same value as "current full scale correction" will be displayed, such as "0.6872". At this time, the multimeter can be connected



in series to the positive pole of 4-20mA output. If the output current is 20.00mA, the error of ± 0.02 mA is normal.

4.6 Sensor parameters

4.6.1 Measuring pipe diameter (couldn't modification)

This has been set before the factory, please do not make any changes. For example, the DN250 flowmeter will display "0250 mm" in this menu.

4.6.2 Excitation frequency selection (couldn't modification)

This is determined by the manufacturer according to the hardware characteristics, please do not modify.

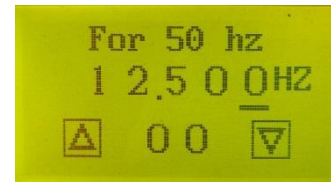

4.6.3 Sensor coefficient value(couldn't modification)

This parameter is the value measured after the water pump in the factory is calibrated and printed on the name plate. The factory coefficient of each set is different. This value is a value with 4 decimal places, such as 1.5882. The range is 0.0000-3.9999.

4.6.4 Allowable velocity correction

Default: forbidden; you can select allow. Only when "allow" is selected, the following "velocity correction point 1" to "velocity correction point 5" will work.

4.6.5 Velocity correction point 1

This refers to the flow rate measured at the first measuring point, and the initial value is "00.000m/s".

4.6.6 Velocity correction number 1

This refers to the difference between the measured flow rate and the actual value at the first measuring point. For example, the flow rate measured by the flowmeter is "01.350m/s", the actual flow rate is "01.450m/s", $01.450\text{m/s} - 01.350\text{m/s} = 00.100\text{m/s}$. and input "00.100m/s".

4.6.7 Velocity correction point 2

This refers to the flow rate measured at the second measuring point, and the initial value is "00.000m/s".

4.6.8 Velocity correction number 2

This refers to the difference between the measured velocity at the second measuring point and the actual value, and the calculation method is in accordance with the "velocity correction number 1".

4.6.9 Velocity correction point 3

This refers to the flow rate measured at the third measuring point, and the initial value is "00.000m/s".

4.6.10 Velocity correction number 3

This refers to the difference between the measured velocity and the actual value at the third measuring point. The calculation method is based on the "velocity correction number 1".

4.6.11 Velocity correction point 4

This refers to the flow rate measured at the fourth measuring point, and the initial value is "00.000m/s".

4.6.12 Velocity correction number 4

This refers to the difference between the measured velocity and the actual value at the fourth measuring point. The calculation method is based on the "velocity correction number 1".

4.6.13 Velocity correction point 5

This refers to the flow rate measured at the fifth measuring point, and the initial value is "00.000m/s".

4.6.14 Sensor code 1

The sensor code records the delivery time of the matching sensor.

4.6.15 Sensor code 2

The sensor code records the factory number of the matching sensor.

4.7 Communication parameter setting

4.7.1 Instrument communication mode

This flowmeter provides three communication modes: MODBUS, HART Communication (loaded on 4-20mA), PROFIBUS, and corresponding communication modes should be set when different communication modes are selected for non full tube flowmeter.

4.7.2 Instrument communication address

It refers to the communication address of this flowmeter during 485, HART and PROFIBUS communication. The range is from 01~250 address. The address 0 is reserved and must not be the same as the address of other devices on the same bus.

4.7.3 Instrument communication speed

Communication baud rate selection range:300, 600, 1200, 2400, 4800, 9600, 19200, 38400.

4.7.4 Instrument calibration mode

The standard configuration is 8-bit non parity mode of standard Modbus communication. Users can select 8-bit odd check mode and 8-bit even check mode according to their needs.

① 8-bit no check mode

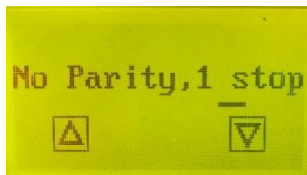

② 8-bit parity mode



③ 8-bit odd check mode

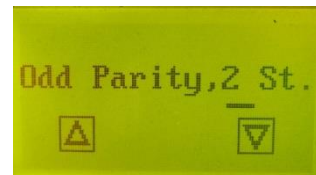

4.8 Instrument factory parameters

4.8.1 Security code 1

Enter the menu, display "00000", and set the primary protection password.

4.8.2 Security code 2

Enter the menu, display "00000", set the secondary protection password.

4.8.3 Security code 3

Enter the menu, display "00000", set the three-level protection password.

4.8.4 Security code 4

Enter the menu, display "00000", set the four-level protection password.

4.8.5 Instrument code 1

Set the factory date of the instrument.



4.8.6 Instrument code 2

Set the factory number of the instrument.

4.8.7 Positive total low post

The initial value is "00000", which is used to set the accumulated flow rate of positive flow direction by five digits, which is generally used to replace the transmitter. The user can modify the positive cumulant ($\Sigma+$) by using a five-level password. Generally, the cumulant cannot exceed the maximum value of the counter (999999999).

4.8.8 Positive total high post

The initial value is "0000", which is used to set the high 4-digit value of the accumulated flow in the positive flow direction, which is generally used to replace the transmitter. The user can modify the positive cumulant ($\Sigma+$) by using a 5-level password. Generally, the cumulant cannot exceed the maximum value of the counter (999999999).

4.8.9 Reverse total low post

The initial value is "00000", which is used to set the accumulated flow rate of reverse flow direction by 5 digits, which is generally used to replace the transmitter. The user can modify the reverse cumulant ($\Sigma-$) by using a 5-level password. Generally, the cumulative amount cannot exceed the maximum value of the counter (999999999).

4.8.10 Reverse total high post

The initial value is "0000", which is used to set the accumulated flow in the reverse flow direction to 4 digits higher, which is generally used for replacing the transmitter. The user can modify the reverse cumulant ($\Sigma-$) by using a 5-level password. Generally, the cumulative amount cannot exceed the maximum value of the counter (999999999).

4.9 Level parameters

The liquid level measuring unit outputs 4-20mA current signal, corresponding to the range of liquid level, 4mA corresponds to zero level, 20mA corresponds to full level.

4.9.1 Level zero correction

Input 4mA liquid level signal and adjust the zero point correction parameter of liquid level to make the flowmeter display 0% liquid level.

4.9.2 Level range correction

Input 20mA liquid level signal, adjust the liquid level full degree correction, make the non full tube flowmeter display 100.0% liquid level.

4.9.3 Level alarm allowed

Default: forbidden; you can select allow. If the liquid level alarm is set as "allowed", "level upper limit alarm" and "level lower limit alarm" can be set. After setting, when the liquid level is lower than the set value of the lower limit alarm or higher than the set value of the upper limit alarm, an alarm will be displayed.

When the operating liquid level is lower than this value, the liquid level percentage will be cut off and LEV liquid level alarm will be prompted.

At this time, the instantaneous flow rate of the transmitter is 0, the flow rate is normal, the output pulse is "0", and the current output is the signal "0" (4mA).

4.9.4 Level upper limit alarm

The initial value is "1000.0mm", can be set by yourself.

4.9.5 Level lower limit alarm

The initial value is "0000.0mm" , can be set by yourself.

4.9.6 Level mode selection

Default: allow; you can select disable.

If the parameter is set to "positive", then 4mA corresponds to zero level and 20mA corresponds to full level;

If the parameter is set to "reverse", then 20mA corresponds to zero level and 4mA corresponds to full level;

If the parameter is set to "disable", the liquid level does not participate in the calculation of instantaneous flow, that is, the liquid level measurement function does not work (the parameter is "forbidden" by default);

4.9.7 Level height (couldn't modify)

The initial value is the factory set value. For example, the non full pipe flowmeter of DN250 is "0250.0 mm".

4.10 Characteristics and connection requirements of connecting wires and cables

Warning: when connecting the signal of the sensor, it is absolutely forbidden to mix the signal line A B C with the excitation X Y signal line. If the wrong wiring occurs, the transmitter will be permanently damaged!

4.10.1 Flow signal cable

When the transmitter and sensor are used together, the flow signal transmission cable can use the PVC sheathed metal mesh shielded signal cable of RVVPB2*0.12*280 mm².

The service length should not be greater than 50m.

The signal line and sensor are supplied with factory.

The signal line processing can be carried out according to Fig. 4.4.1.

The transmitter provides output voltage of shielding signal with equipotential excitation to reduce the influence of distributed capacitance transmitted by cable on flow signal measurement. For long distance transmission, dual core double shielded signal cable with equipotential shielding can be used.

4.10.2 Current cable

Two core insulated rubber flexible cable can be used for current line, and the recommended model is RVVP2*0.12*250mm². The length of excitation current line is consistent with that of signal cable.

4.10.3 Ground connection

The grounding terminal of transmitter shell shall be grounded with copper wire no less than 1.6mm².

The grounding resistance from the transmitter housing to the ground should be less than 5 Ω.

4.11 Digital output and calculation

Digital output refers to frequency output and pulse output. Frequency output and pulse output use the same output point on the wiring. Therefore, users can not select frequency output and pulse output at the same time, but only choose one of them.

Frequency output:

The frequency output range is 0-1000hz, and the frequency output corresponds to the flow percentage :

$$F = \frac{\text{Measured value}}{\text{Full scale value}} \bullet \text{Frequency range}$$

.The upper limit of frequency output is adjustable. User option 0 ~ 1000HZ frequency output mode is generally used for control applications because it reflects the percentage flow if the user is used for metering applications.

5. Parameter setting of non full tube flowmeter

After the transmitter and sensor of the non full tube flowmeter are connected to the fluid channel (whether it is calibrated or used), the following work should be carried out first:

- The front and rear straight canal sections with good installation position are selected, that is, the actual installation position.
- Install the non full pipe flowmeter and fix the communication cable of the non full pipe flowmeter.
- When adjusting the zero point of the non full pipe flowmeter, ensure that the fluid in the channel is still.

6. Installation requirements and application of non full tube flowmeter

From the appearance, the non full tube flowmeter is no different from the ordinary flowmeter. It also has the advantages of no movable parts, no flow blocking parts, small pressure loss, no measurement lag phenomenon, linear output and wide range.

The measuring channel of the non full tube flowmeter is a smooth straight pipe, which will not be blocked.

Therefore, it is especially suitable for measuring liquid-solid two-phase fluid containing solid particles, such as pulp, slurry, sewage, etc. Installation of non full pipe flowmeter, its upstream will not raise the water level, so it will not bring head loss.

The liquid level in the pipeline measured by the non full pipe flowmeter is 10% - 100% of the cross-section, and it can maintain good measurement accuracy under the condition of both the full pipe flow and the non full pipe flow rate.

6.1 Wiring

All connecting wires of the non full tube flowmeter shall be as short as possible, and the power line shall be avoided as far as possible (more than 50 cm away from the 220VAC power line, and more than 150 cm from the 380VAC power line). The waterproof, moisture-proof, anti breaking and shielding treatment of the connecting wires shall be done to ensure the correct wiring.

6.2 Zero adjustment (automatic system Zeroing)

When the installation, wiring and parameter setting of the non full tube flowmeter are completed, zero adjustment is required before formal use. Adjustment method: enter the parameter setting menu, find "zero point calibration", press the right shift key, move the cursor to the rear zero of the number, press the up key once to set the value to 1, and then press the right shift key again to enter the zero automatic debugging status State, the zero point automatic debugging time is 60 seconds, at this time, the downward digital flashing gradually reduces from 60 to zero, and the zero automatic debugging is finished. Before using or calibrating the non full tube flowmeter, zero adjustment should be carried out. In the process of automatic zero adjustment, the static state of the measured medium must be ensured.

6.3 Field calibration

During calibration, it is necessary to ensure that the overflow at the measurement section is constant within a certain period of time, otherwise the same water level will correspond to different flow in the process of water rising or falling, resulting in larger (falling) or smaller (rising) of calibration coefficient results; another thing to pay attention to is to select one or several suitable water levels for calibration, and extreme water level can not be selected; when the actual situation is met, the same water level will correspond to different flows, resulting in the calibration coefficient result being too large (falling) or too small (rising water) When the accurate value of cross-section flow cannot be obtained, the system error can be offset by installing instruments by symmetrical method or reverse method.

6.4 Maintenance

- ① Keep the display installation place dry and ventilated, as well as normal power supply.
- ② On site equipment to prevent man-made damage.

7. Alarm information

The printed circuit board of non full tube flow transmitter adopts surface welding technology, which is not repairable for users. Therefore, the user is not allowed to open the transmitter housing.

The non full tube flowmeter has self diagnosis function. In addition to the power supply and hardware circuit failure, the fault in general application can give the alarm information correctly.

These messages will indicate "!" after the flow on the upper left of the display.

In the measurement state, the second page of the non full tube flowmeter automatically displays the following fault contents:



Upper and lower limit alarm prompt 1



Empty tube alarm prompt 2



Excitation alarm prompt 3

8. Troubleshooting

8.1 No indication for non full tube flowmeter

- * Check whether the power supply is connected;
- * Check whether the power fuse is in good condition;
- * Check whether the power supply voltage meets the requirements;

8.2 Alarm

- * Whether wiring X and Y are open circuit;
- * Whether the total resistance of the sensor is less than 100Ω ;
- * If both a and b are normal, the transmitter is faulty.

8.3 Output display shaking

- * Measure whether the fluid is stable;
- * Check whether the signal connection is firm;
- * Check whether the sensor electrode is normal and contaminated:

Under the condition of flow rate, the resistance of terminals A and B to C shall be less than 50kΩ (water measurement value for medium). It is better to use a pointer multimeter to measure, and the phenomenon of charge and discharge can be seen in the measurement process).

8.4 The measured flow rate is not accurate

- * Whether the water level signal conforms to the actual value;
- * Whether the signal line connection is normal;
- * Check whether the sensor coefficient and sensor zero point are set according to the sensor label or factory calibration sheet;



Appendix 1 Description of nonlinear correction function

In principle, the nonlinear correction function is used for linear adjustment under small flow (0.5m/s). The function is designed with four correction sections, which are divided into four flow points and four correction coefficients. The flow corresponding to the correction point must meet the following requirements: correction point 1 > correction point 2 > correction point 3 > correction point 4 > 0.

The correction calculation is based on the original sensor flow coefficient curve. Therefore, the nonlinear correction function should be turned off first and the sensor coefficient should be marked. Then, the nonlinear correction function is allowed.

In the formula, the original flow is the real standard flow, and the corrected flow is called the corrected flow. The modified calculation formula is as follows:

When Correction point 1 > Original flow \geq Correction point 2;

Corrected flow = correction factor 1 \times Original flow;

When Correction point 2 > Original flow \geq Correction point 3;

Corrected flow = correction factor 2 \times Original flow;

When Correction point 3 > Original flow \geq Correction point 4;

Corrected flow = correction factor 3 \times Original flow;

When Correction point 4 > Original flow \geq 0 ;

Corrected flow = correction factor 4 \times Original flow;

Note: when setting correction points, the following relationships should be maintained:

Correction point 1 > Correction point 2 > Correction point 3 > Correction point4 > 0

The median value of the correction coefficient is 1.0000.

If the coefficient is greater than 1, the flow will be corrected to be high, and if the coefficient is less than 1, the flow will be corrected to be low.

Technical information

The model selection of the electromagnetic flowmeter is preferably performed by a technician who is familiar with on-site technological conditions. The technician shall select proper aperture, lining material and electrode and so on according to the measurable range table in the type selection material, and the selection is preferably confirmed by an end user who is familiar with the on-site technological conditions

■ Selecting flow meter type:

Integral type and the Remote split type

Both integral type and remote split type have their own advantages, and basic principles for selection are as follows: the split type is usually used in situations inconvenient for one-site maintenance and numerical reading when debugging is difficult or the flow meter is often immersed in water and with other functions. It is also used in poor application situations, such as high temperature fluid, a position with vibration source and explosive environment. In most cases, both the integral type and the remote split type can meet use requirements.

General type and explosion-proof type

Users shall confirm to select a general type or an explosion-proof type according to application environment of the flow meter.

■ The diameter of the sensor and that of technological pipeline:

Generally, it's suggested not to select reducing pipe for the sake of convenient installation, provided that the use flow in the flow meter pipe shall be within the range of 0.3m/s~10m/s. This kind of selection is usually applicable to a newly-designed project for which current work situation is not only considered when choosing a flow speed, but also a situation of running at full load of the device in the future shall also be considered. For the relationships among the flux, velocity and diameter, see curve graph. However, sometimes we also choose a sensor with a different diameter with the connected technological pipeline diameter, for example:

1. The velocity in the pipeline is low and the process flux is stable. In order to meet the demand of instrument for flux range and improve local velocity of the flow meter, select a sensor with smaller diameter than the technological pipeline and additionally connect a reducing pipe at front and rear part of the sensor.
2. In terms of large diameter electromagnetic flow meter, the larger the diameter is, the higher the price will be.. As for the situations with low velocity in the pipeline and stable technological parameter, small diameter flow meter may be chosen. This not only runs the flow meter under good working state, but also reduces investment cost.

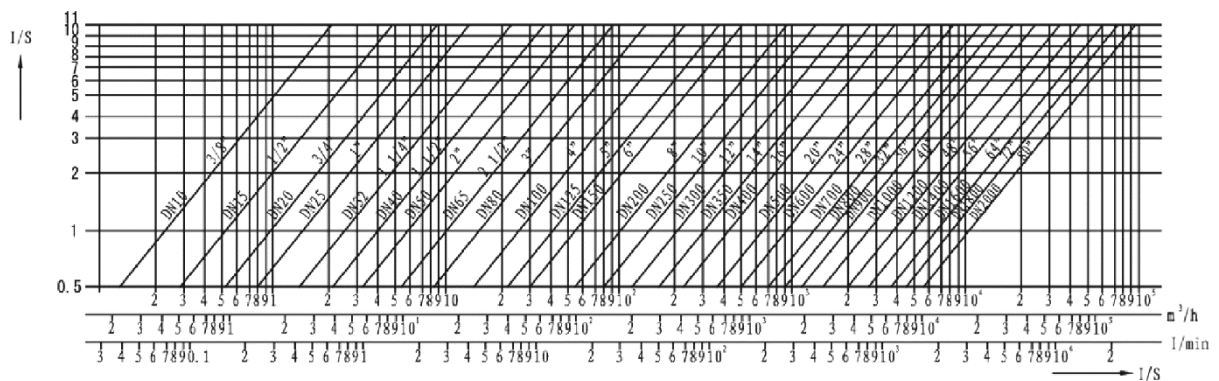

Curve Chart of the Relationships among the Diameter Velocity and Flux of Flowmeter

Length of straight pipe segment:

To guarantee the upstream pipeline condition required for achieving high measurement precision of electromagnetic flow meter, pipeline condition as shown in following figure are recommended according to standards above and measured data of pipeline condition.

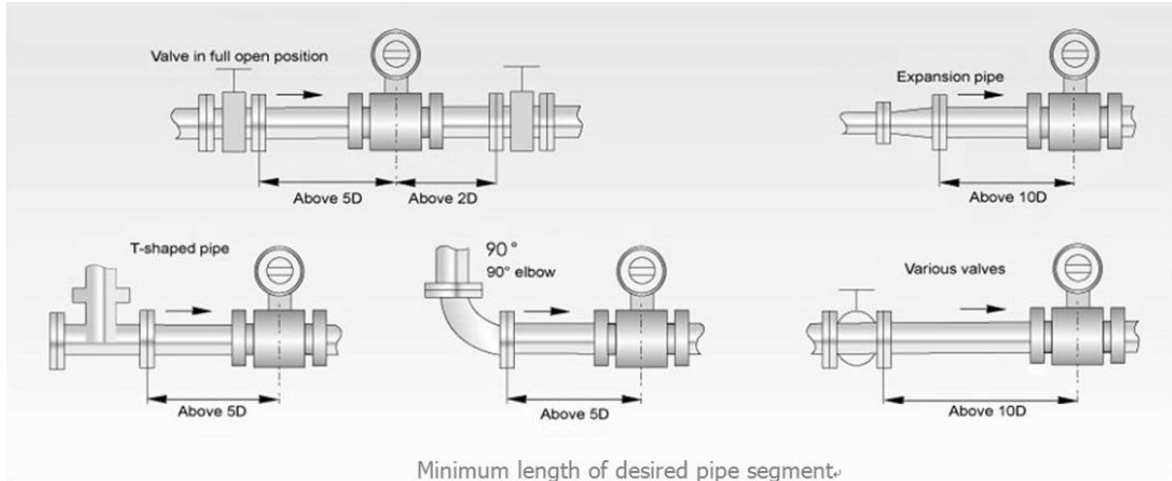

Notes for additionally installing a reducing pipe:

Selection of a reducing pipe cone angle

For not mapping distribution of flow field after installing the reducing pipe, and not influencing precision of the electromagnetic flow meter, the reducing pipe can be regarded as one part of the straight pipe segment. The central cone angle α of the reducing angle shall be no more than 15 degrees, and the smaller the better.

Installing a reducing pipe will cause pressure loss

Total pressure loss composes pressure loss in the gradual contraction pipe by three parts:

Pressure loss of a gradual contraction pipe $\Delta P_1 = \rho/2\xi_1 V^2$

Pressure loss of a gradual enlargement pipe $\Delta P_3 = \rho/2\xi_3 V^2$

Pressure loss in the sensor measurement pipe $\Delta P_2 = \rho/2\xi_3 V^2$

The total pressure loss is:

$$\Delta P = 0.01 (\Delta P_1 + \Delta P_2 + \Delta P_3) \text{ (mbar)}$$

Where, ρ is a medium density, whose unit is kg/m^3

ξ_1 ξ_3 are respectively coefficients related with the Reynolds number of reducing pipe and increasing pipe.

$\xi_2 = 0.02$ is coefficient of sensor measuring pipe.

V_1 and V_2 are respectively velocities in the technological pipeline and sensor measurement pipe, whose unit is m/s.

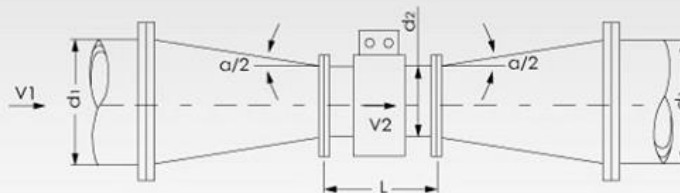

E.g. the value of ζ when $\alpha=80$

d_1/d_2	1.2	1.3	1.4	1.5	1.6	1.7	1.8	1.9	2.0
ζ_1	0.018	0.023	0.0255	0.028	0.03	0.0308	0.0315	0.0323	0.0332
ζ_3	0.01	0.02	0.07	0.15	0.26	0.43	0.64	0.9	1.25

Installation direction:

When installing an electromagnetic flow meter, generally speaking, the axis line of the electrode shall be approximate level in horizontal installation; if the axis line of the electrode is perpendicular to the ground, bubbles will be easily collected near the electrode located on the upper side, the electrode located at lower side and stopping the liquid contacting with the same is covered by slurry. The converter shall be installed above the pipeline to prevent water from entering the converter.

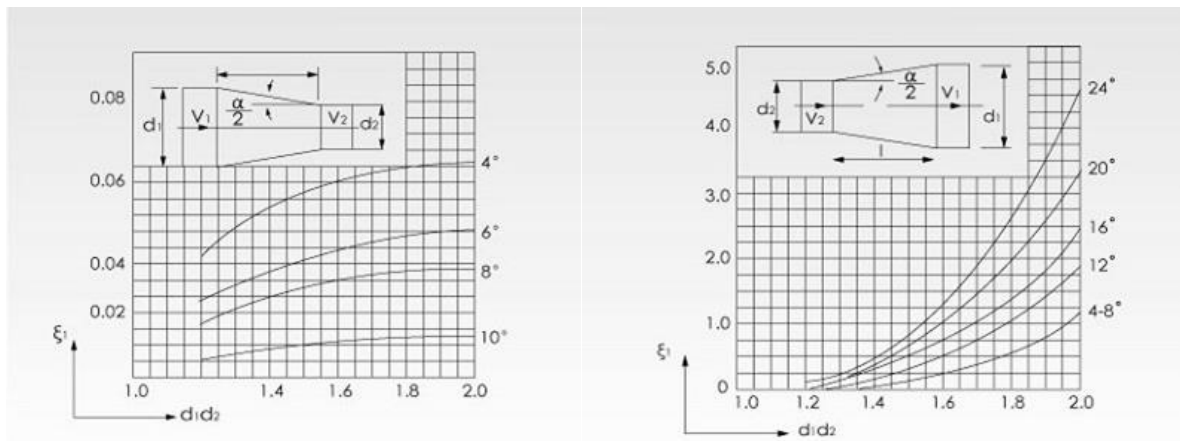
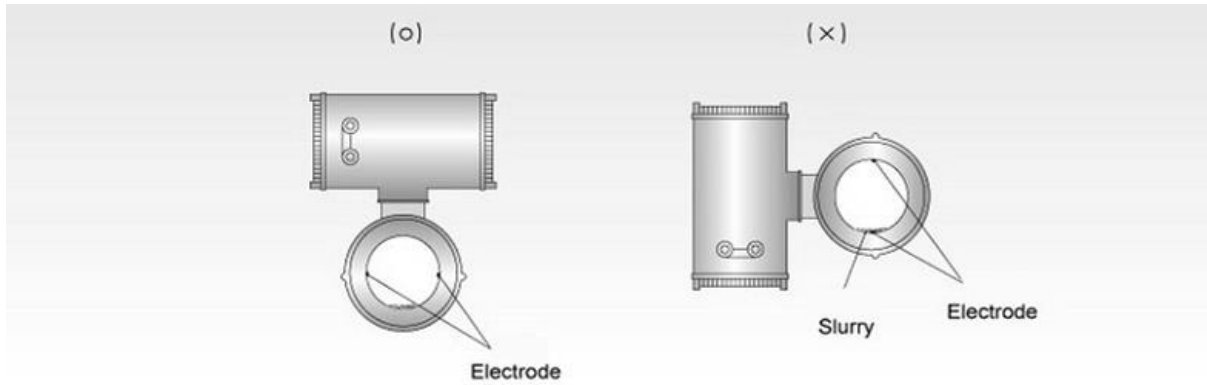

Gradual contraction pipe

Gradual enlargement pipe

The positive direction in which fluid flows is generally in the same direction as the arrows in the sensor. There must be an enough installation and maintenance space close to the flow meter to prevent the flow meter from being vibrated. During installation of the flow meter, supports for supporting pipelines should be provided on the two sides of the flow meter. Stress is prevented from being affected because of pipeline vibration, impact and shrinkage. For heavy polluted fluid, a consideration that a flow meter is installed on the pipeline should be given.

Electromagnetic flowmeter must work in full pipe conditions; that is to say, the flowmeter cannot normally work in part-filled pipe or empty pipe conditions.

Flow meter piping:

Misalignment or inclination of pipeline is a reason why the pipeline flange bounces and breaks.

- (1) During installation of flow meter, misalignment or inclination of pipeline, and installation distance deviation between two flanges should be corrected first.
- (2) During installation of flow meter, generally there are some foreign matters (e. g. welding slag and scraps) within pipeline road. Prior to installing the flow meter, these impurities should be washed away.

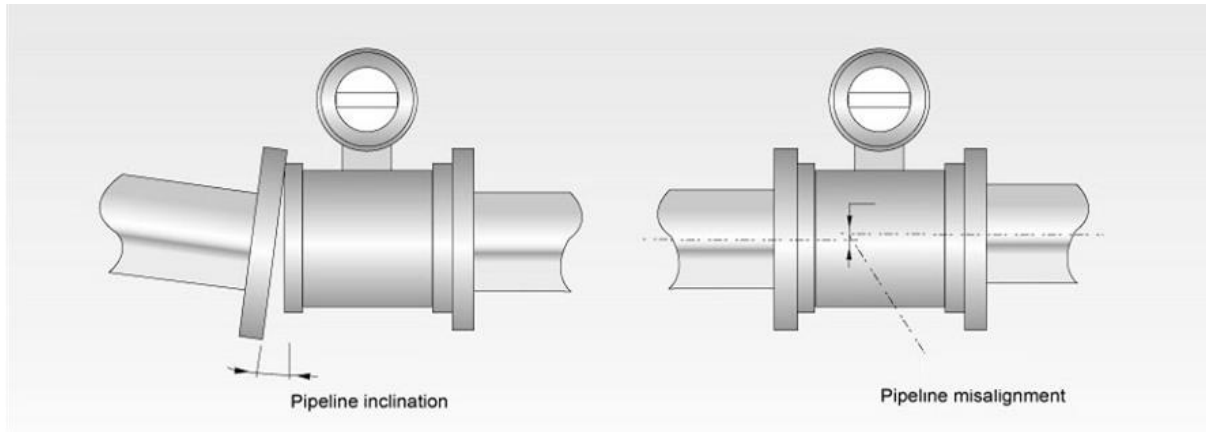

■ Conductivity of fluids:

Electromagnetic flow meter cannot be installed where the conductivity of fluids is very uneven. In particular when chemicals are injected from the upstream of the instrument, it is very easy to cause unevenness of conductivity, thereby seriously interfering the measurement of flowmeter. In this case, we recommend that chemicals should be injected from the downstream of the instrument. If chemicals must be injected from the upstream of the instrument, a straight pipe section which is long enough must be installed to ensure that fluids are mixed well.

■ Liquid sealant:

The following points should be mentioned during using fluid sealant;
 Don't let it cover the surfaces of electrode and grounding ring because this will influence the measurement of fluid flow.

■ Adopting throttle valves and bypass valves:

For convenient maintenance and zero setting, throttle valves and bypass valves are suggested to adopt.

Ensuring no bubble in flowmeter

Pipeline design should ensure that no bubble can be separated from fluid. Generally, the flow meter should be installed in the upstream of the valve, because the pressure in the pipeline is reduced under the action of the valve, thereby producing bubble.

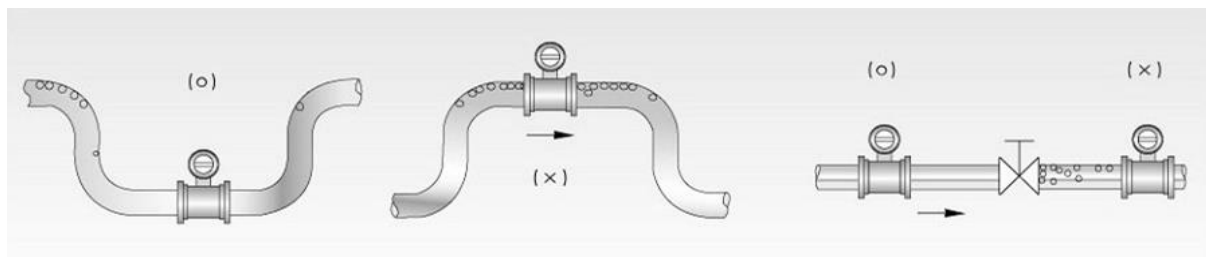

Selection of electrode materials:

Electrode materials should be selected according to corrosiveness of measured medium, and selected by users familiar with site conditions. In general, the corrosion resistance of electrode material is higher than that of pipeline material by one grade. For ordinary media, please consult related anti-corrosion manuals. For media having complex components such as mined acid, coupon tests should be done.

Properties of electrode material (for reference only):

Electrode material	Properties of measured material (for reference only)	Corrosion reference
316 TI	Domestic water, industrial water, raw well water, urban sewage, weak corrosive acid, alkali, salt solutions.	
Hastelloy alloy B (HB)	Hydrochloric acid (concentration less than 10%), and other non-oxidizing acids Sodium hydroxide (concentration less than 50%), all concentrations of alkali-ammonium hydroxide solution Phosphoric acid, organic acids	Not apply to nitric acid
Hastelloy alloy C (HC)	Mixed acids such as chromic acid and sulfuric acid solution Oxidizing salts such as Fe ⁺⁺⁺ , Cu ⁺⁺ , water	Not apply to hydrochloric acid
Titanium	Salts, such as (1)chloride (ammonium oxide/calcium/magnesium/Aluminum/iron/etc) (2) the sodium salt, potassium salt and ammonium salt and sodium hypochlorite salts, as well as potassium hydroxide, ammonium hydroxide, barium hydroxide caustic soda solution with sea water concentrations less than 50%	Not apply to hydrochloric acid, sulfuric acid, phosphoric aci hydrofluoric acid and other reducing acid
Tantalum	Hydrochloric acid (concentration less than 40%). dilute sulfuric acid and concentrated sulfuric acid (not including oleum) Chlorine dioxide, ferric chloride, hypochlorite, sodium hydroxide, lead acetate Nitric acid (including fuming nitric acid) and other oxidizing acid, aqua regia with temperature below 80 degrees centigrade	Not apply to alkali and hydrofluoric acid
Platinum	Almost all of the acid, alkali, salt solutions (including fuming sulfuric acid, fuming nitric acid)	Not apply to aqua regia, ammonium salt
Tungsten Carbide	Pulp, sewage, solid particles with anti-interference property	Not apply to inorganic acids, organic acids, chlorides

Selection of grounding ring material:

Grounding ring material can be the same as the electrode material; generally material with the same corrosion resistance as the pipeline material is selectable.

Selection of lining material:

Lining material should be selected according to the type and working temperature of measured fluid. PFA is a fluorinated plastic, has good corrosion resistance to strong acid, strong alkali, at the same time has good high temperature resistance, does not deform at high temperature. Insulation resistance is not reduced. 99.9% high purity alumina is used for making ceramic lining so that the instrument can measure the flow with high precision.

In comparison with traditional high polymer material, ceramics cannot create high temperature, high pressure deformation, and have good wear resistance.



Selection of protection grade:

Degrees of protection provided by enclosure are as follows according to GB4208-84, International Electro-technical Commission (IEC) standards (IEC529-76):

IP65 is an anti-spray type, i.e. a water faucet is allowed to spray water to the instrument in any direction. The pressure of spray water is 30KPa (0.3bar). Water yield is 12.5 liters/minute. The distance between spray water and the instrument is 3m. IP67 is an anti-immersing type, i.e. the instrument can be totally immersed in the water in a short time. The highest point is 150cm below the water during test. The duration time is 30min. IP68 is a submerged type, which can work in the water for a long period. The maximum depth immersed is negotiated by manufacturers and users.

The selection principles of protection grade are determined by the abovementioned requirements and actual working conditions of the instrument. If the instrument is installed underground and often immersed under water, it's suggested to select IP68. If the instrument is installed above the ground and the environment is not wet, choose IP65.

Sensor ground:

Because the voltage of sensing signals of the electromagnetic flow meter is small, it is easily affected by the noise. The reference potential must be the same as the measured fluid. So the reference potential (terminal potential) of the sensor, the reference potentials of converter and amplifier are the same as the measured fluid. And the fluid potential should be the same as the ground potential. The electromagnetic flow meter is equipped with a grounding ring, which plays a role in establishment of fluid ground by contacting the fluid, at the same time, protecting the lining. The instrument ground is as shown below:

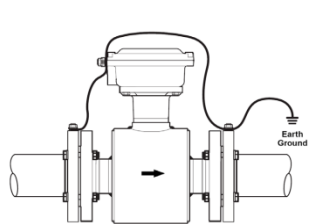
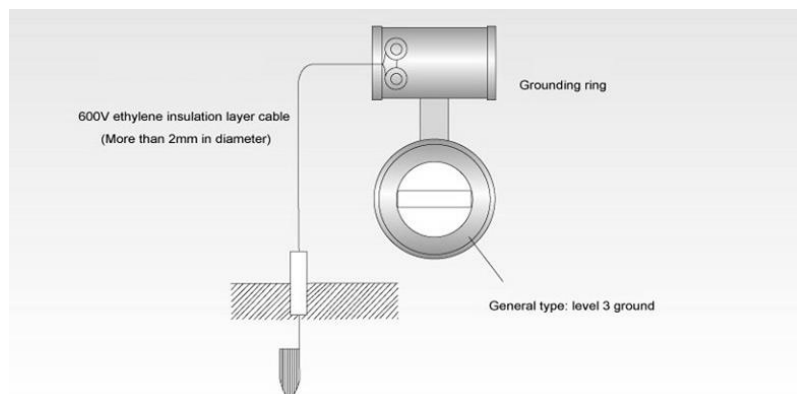

No Grounding Options or Grounding Electrode in Lined Pipe

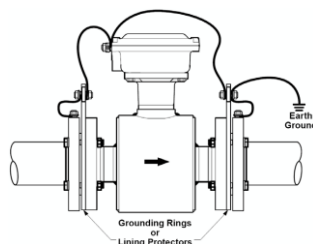

Grounding with Grounding Rings or Lining Protectors

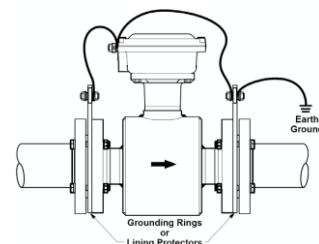

Grounding with Grounding Rings or Lining Protectors

Noise suppression:

The electromagnetic flow meter cannot be installed near the motor, transformer or other power supplies easy to cause inductive interference.

Main properties and application range of electromagnetic flow meter lining:

Lining	Material	Main Properties	Application Range of Lining	Examples of Measurable Media	Notes
Teflon	PTFE	<ol style="list-style-type: none"> 1. Chemical stability is good, but chlorine element and metal sodium in the melting state have a certain corrosion resistance to the product. 2. It is hydrochloric acid, sulfuric acid and aqua regia-resistant and organic solvent has no effect on it. 3. Bad wear resistance and adhesive properties, excellent electrical insulating property, but bad corona resistance. 	<ol style="list-style-type: none"> 1. Long term usage temperature of the flowmeter is -10 ~+120°C 2. For use in measurement of most of strong corrosive media such as strong acid, alkali, oxidant, but not suitable for KOH, nitric acid, hydrofluoric acid, etc. 3. Health media 	<ol style="list-style-type: none"> 1. Hydrochloric acid, sulfuric acid, aqua regia. 2. Other most strong acids, alkalis and 	<ol style="list-style-type: none"> 1. Not suitable for KOH, nitric acid, hydro fluoric acid. 2. Generally not for use in measurement of electrolyte, e. g. NaCl solution from electrolytic tank. 3. Not suitable for media with solid particles.
	FEP	<ol style="list-style-type: none"> 1. Its chemical stability, electrical insulation property, lubricating property, non-stick property and incombustibility are similar with PTFE (F4), but the strength, aging resistance, temperature resistance and low temperature flexibility of FEP material are superior to PTFE. 2. Adhesion with metal is good; wear resistance is better than PTFE. 3. High tearing resistance 	<ol style="list-style-type: none"> 1. Long term usage temperature of the flowmeter is -40~+150°C 2-For use in measurement of most of strong corrosive media such as strong acid, alkali, oxidant, but not suitable for KOH, nitric acid, hydrofluoric acid, etc. 3-Health media 	<ol style="list-style-type: none"> 1. Hydrochloric acid, sulfuric acid, aqua regia. 2. Other most strong acids, alkalis and oxidants. 3. Media with less fine particles. 	<ol style="list-style-type: none"> 1. Not suitable for KOH, nitric acid, hydrofluoric acid. 2. Generally not for use in measurement of electrolyte, e. g. NaCl solution from electrolytic tank.
	PFA	<ol style="list-style-type: none"> 1. Its chemical stability, electrical insulation property, lubricating property, non-stick property and incombustibility are similar with FEP(F46), but the strength, aging resistance and temperature resistance of PFA material are superior to PTFE, FEP. 2. Adhesion with metal is good; wear resistance is better than PTFE, FEP 3. Low smoke, fire resistance, high temperature resistance. High temperature mechanical strength is two times higher than PTFE. 	<ol style="list-style-type: none"> 1. Long term usage temperature of the flowmeter is -40~+160°C 2. For use in measurement of most of strong corrosive media such as strong acid, alkali, oxidant, but not suitable for KOH, nitric acid, hydrofluoric acid, etc. 3. Health media 	<ol style="list-style-type: none"> 1. Hydrochloric acid, sulfuric acid, aqua regia. 2. Other most strong acids, alkalis and oxidants. 3. Media with less fine particles. 4. Beer, saponified liquefied gas, etc. 	<ol style="list-style-type: none"> 1. Not suitable for KOH, nitric acid, hydrofluoric acid. 2. Generally not for use in measurement of slurry, coal pulp and core pulp.
Polyurethane Rubber	<ol style="list-style-type: none"> 1. Excellent wear resistance, good oil resistance. 2. High strength good tearing resistance, bad acid and alkali resistance. 3. Bad heat resistance, generally 60°C 	<ol style="list-style-type: none"> 1. Long term usage temperature is generally -10~+80°C 2. Good wear resistance, suitable for fluid containing solid particles. 3. Not for use in measurement of water containing organic solvent. 	<ol style="list-style-type: none"> 1. Neutral and strong wearing ore pulp, coal pulp and mud. 2. Domestic water, industrial water, sewage and sea water. 	<ol style="list-style-type: none"> 1. The temperature of fluid ranges between 0 and 40°C 2. Generally not for use in measurement of media of organic solvent. 	
Chloroprene Rubber	<ol style="list-style-type: none"> 1. Good elasticity and tearing resistance, oil resistance. 2. Bad aging resistance, its brittleness temperature is -28°C 3. Wear resistance is inferior to polyurethane rubber. 4. Corrosion resistance to ordinary low concentration acid, alkali and salt media, non-corrosion resistance to oxidizing media. 	<ol style="list-style-type: none"> 1. Long term usage temperature is -10~+80°C 2. Slight pollution because anti-aging agent is contained therein. 3. Suitable for measurement of low concentration acid, alkali, salt media and sewage. 	<ol style="list-style-type: none"> 1. Normal water, sewage 2. Slurry, ore pulp 	<ol style="list-style-type: none"> 1. Not for use in measurement of food. 2. Not suitable for measurement of strong acid, alkali, oxidizing media. 	
Ceramics	<ol style="list-style-type: none"> 1. Non-deformation at high strength, high temperature and high pressure. 2. Unique platinum-alumina metal ceramic electrode. 3. Good anti-slurry and anti-noise ability, suitable for permeable fluid. 4. Good wear resistance, which is ten times the polyurethane. 	<ol style="list-style-type: none"> 1. Suitable for high-temperature high-pressure fluid, viscous fluid, corrosive fluid. 2. Permeable fluid, slurry containing solid particles. 	<ol style="list-style-type: none"> 1. Slurry containing hard solid, corrosive fluid, viscous fluid, high-temperature high-pressure fluid. 2. Chromium sulfate, 25% of sodium, hypochlorite, nitric acid, etc. 	<ol style="list-style-type: none"> 1. Not suitable for hydrofluoric acid, nitric acid, aqua acid, NaOH, 70% concentration of sulfuric acid. 2. Not for use in partial salt substances such as copper sulfate, sodium bicarbonate. 	

The our technical specifications may be revised for update without prior notice